

# MULTIPLE BANDING MACHINE

## model series MB

inline banding of product pile rows  
- the ideal solution behind folding machines and guillotines

- » automatic banding of higher volumes of square-cut products
- » applicable for mixed sheets (patented machine system)
- » available in banding widths of 54, 74 and 104 cm
- » up to 12 banding stations allow highly efficient banding
- » delivery to the left or right side





# MULTIPLE BANDING MACHINE

model series MB

## High volume banding - inline or offline

- » installation directly linked to all known guillotines (electric and pneumatic connections are not necessary)
- » increased guillotine output due to a more effective workflow and user-friendly handling of cut paper piles
- » the integrated feed pusher allows an automatic workflow
- » programmable sealing and cooling times for perfect banding results
- » recommended solution also for banding paper piles of different lengths and widths (mixed sheets) due to patented machine system
- » high productivity due to staff savings



## Workflow

1. Operator is loading the feed table with the cutting stacks to be banded.
2. Feed pusher is moving to the end of the product row and is pushing the stacks to the separating plate.
3. Separating plate is moving the first product row to the end position.
4. Additional pusher is moving the product row into the banding station.
5. Sealing bar is sealing the product row while the feed pusher is moving the remaining stacks to the separating plate for banding the next product row.

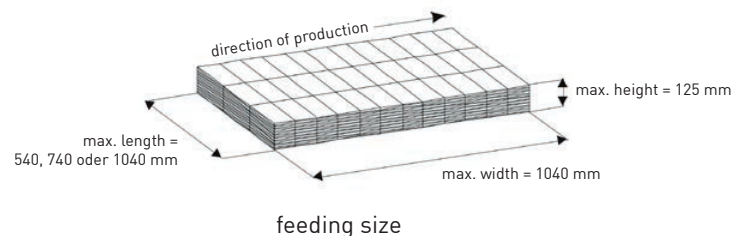

## Intuitive and user-friendly control

- » central adjustment of banding stations
- » tool-free format adjustment in only 1 - 2 minutes
- » adjustable transport speed for product rows
- » safety light barrier and safety hood at delivery side guarantee maximum safety
- » height of table plate (900 mm) is adjustable by +/- 20 mm
- » roller delivery with height adjustment for easy unloading
- » maintenance-free, no periodic lubrication is required



## Touch screen control panel

- » input of sealing parameters (banding material, sealing and cooling times)
- » display of error messages

## Options

- » additional banding station(s)
- » sealing bar for Kraft paper banding
- » spare sealing bar for foil tape banding
- » replacement pad rail

## Additional control panel

- » allows operation of automatic mode from the machine rear side (start, stop and interruption)

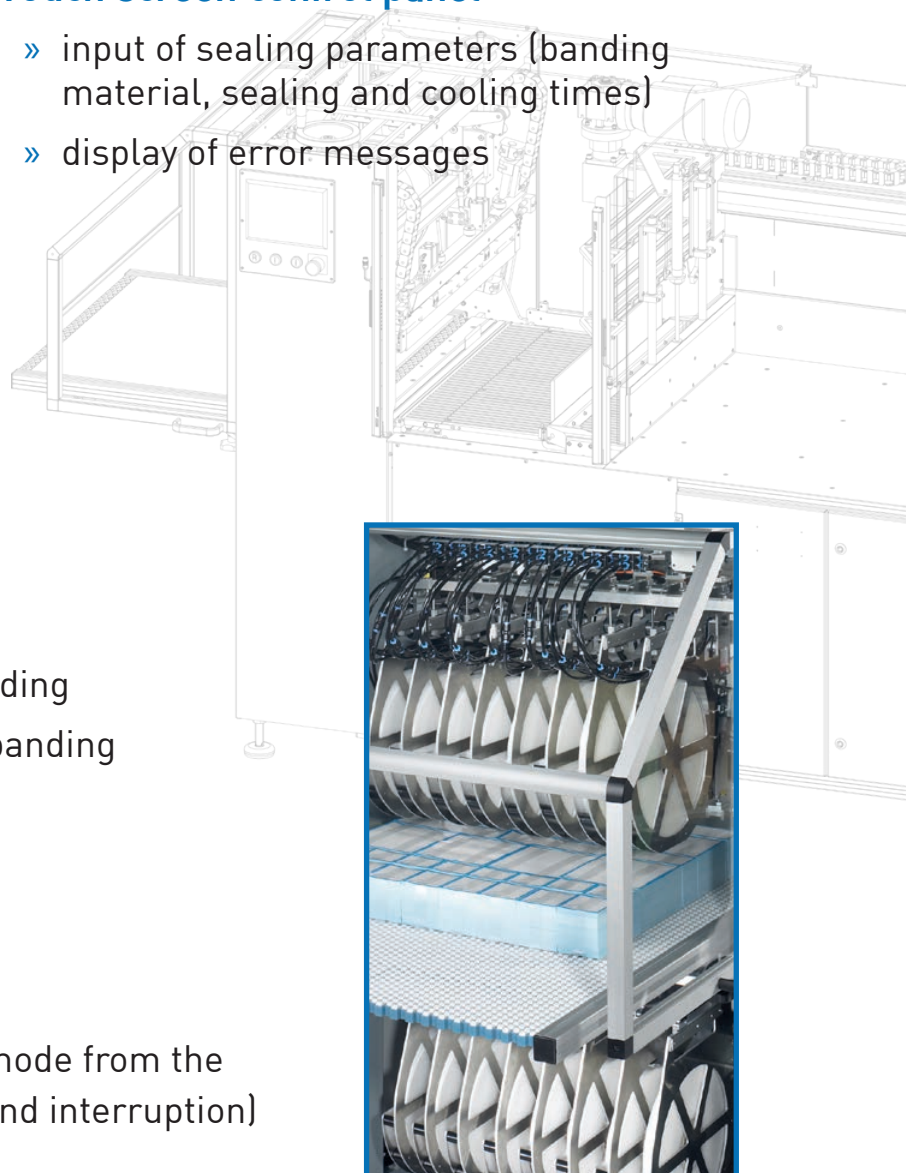



## BANDING MATERIAL

Banding with Polyethylene Flat Film or coated Kraft Paper Tape from Gerhard Busch GmbH

- » tape width 25 mm  
alternative: 20, 30 or 40 mm
- » standard: Polyethylene Flat Film (LDPE 80 µm)  
transparent, reel length: approx. 800 m
- » option: Kraft Paper Tape  
(70 g coated on one side with 30 g of Polyethylene (PE))  
brown, reel length: approx. 550 m



Technical data		MB 54	MB 74	MB 104
Max. feeding size (L x B)	mm	540 x 1040	740 x 1040	1040 x 1040
Max. banding size (L x B)	mm	540 x 250	740 x 250	1040 x 250
Min. banding size (L x B)	mm	43 x 25 *	43 x 25 *	43 x 25 *
Max. pile height (H)	mm	125	125	125
Min. pile height (H)	mm	30	30	30
Machine dimensions				
Length	mm	2775	2775	2775
Width (with open door)	mm	920 (1280)	1120 (1480)	1420 (1780)
Height (with open hood)	mm	1735 (2400)	1735 (2400)	1735 (2400)
Net weight	kg	730	810	930
Machine output				
Number of banding stations		4 **	4 **	6 **
Machine output	strokes / min.	8	8	8
Air requirement	nl / min		approx. 160	
Operating pressure	bar		6	
Sound intensity level (EN 13023: 2003)	dB(a)		max. 70	

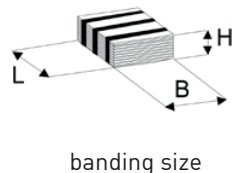
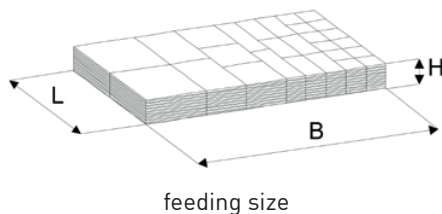

\* Special equipment for minimum sizes on request  
\*\* optional up to 12 banding stations