

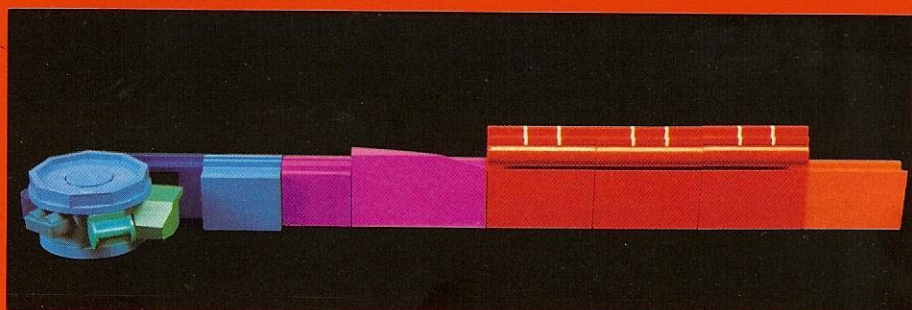

Gathering Machine 201

For separate or in-line operation
with perfect binders



MÜLLER MARTINI

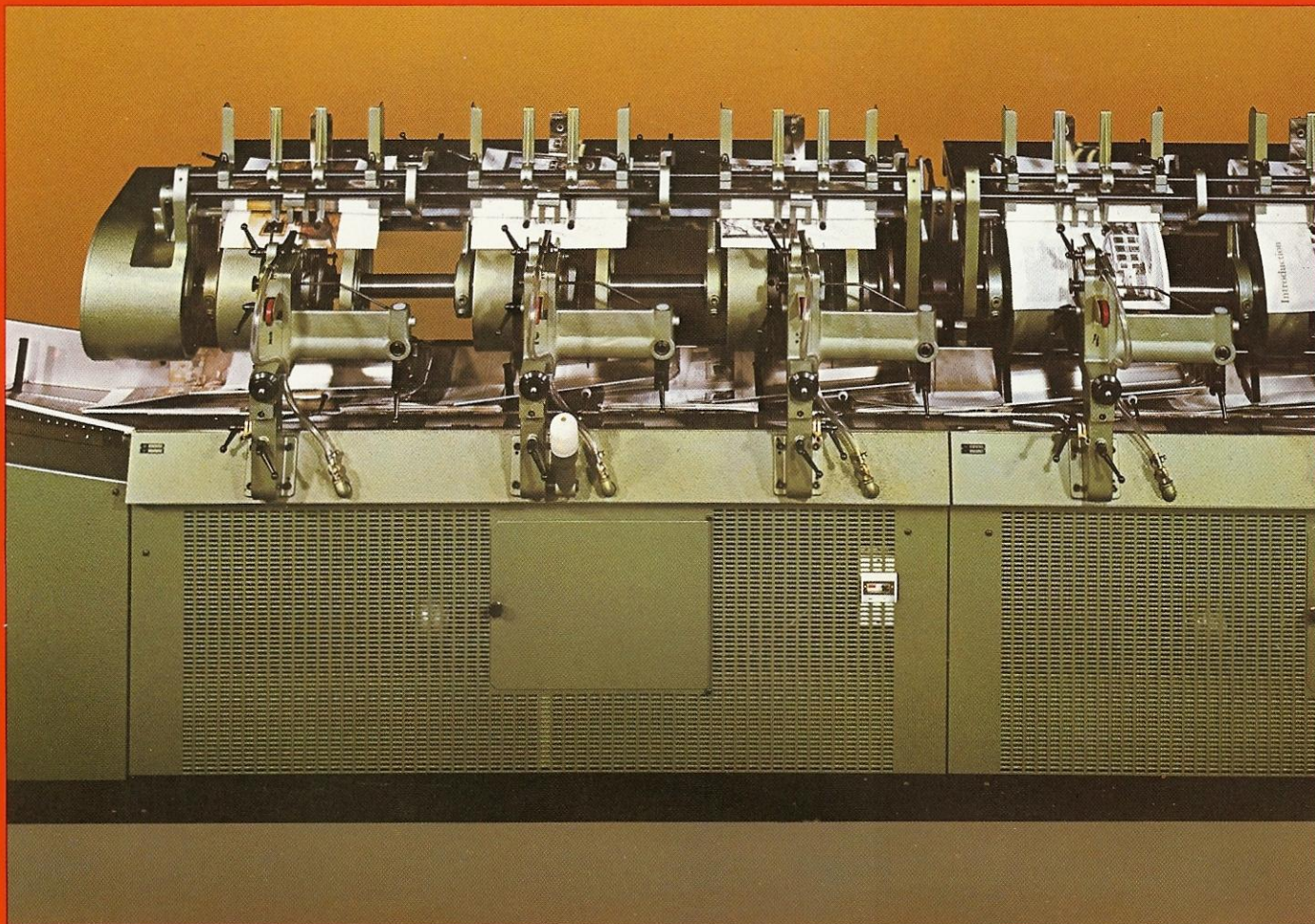

The Building Block Principle of the Gathering Machine, Model 201

The Gathering Machine 201 is furnished in units of 3 stations. Building block design allows expansion to a maximum of 60 feeders. The machine can be used for the production of catalogs, magazines or books. It feeds single sheets and folded signatures efficiently and reliably.

The chain tensioning station at the end of the gathering machine serves as a hand station where one or two persons can manually feed sewn or pregathered book sections or additional signatures.

Each feeding station is equipped with a mechanical miss and double sheet control, which detects missing or double sheets and stops the machine if a fault occurs. Each 3-pocket unit is supplied with its own pressure/vacuum pump.

Size changes and the adjustment of the miss and double sheet control are simple and can easily be made by the operating personnel. If the machine is used for gathering only, there is a choice of deliveries for different types of work.

The gathering machine is equipped with a variable speed AC drive.

Exceptional versatility makes it possible to connect the Gathering Machine 201 to a perfect binder, Model Pony-5 or RB-5. A low-silhouette Gathering Machine, Model 272, is available for connection to the Modular Binder.

Operating Principle

Signatures or single sheets are stacked on the feeder table. The bottom copy is separated from the pile by suction and pulled around the drum by grippers. The remaining copies are held by pile retainers.

This top-loading, bottom-feeding principle assures continuous operation without the need to stop for reloading. A stop in the rotation of the drum assures positive and efficient feeding of even the most difficult stock. Signatures are guided into the raceway, picked up by the pins of the gathering chain and brought to the delivery or an in-line perfect binder.

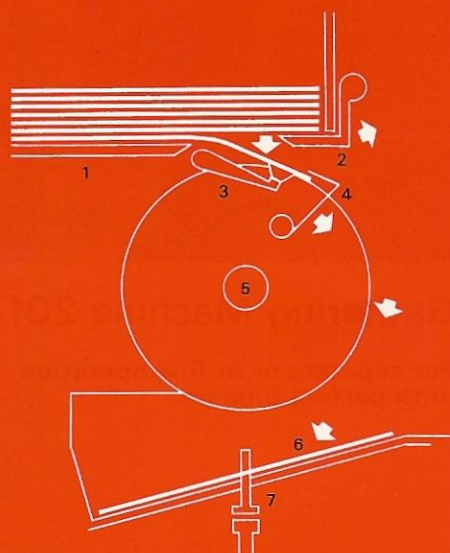

- 1 Feeder table
- 2 Pile retainer
- 3 Suction
- 4 Gripper
- 5 Drum
- 6 Raceway
- 7 Gathering chain

Delivery Units of the Gathering Machine 201

Criss-Cross Delivery

Gathered signatures travel through a spiral raceway and are delivered in the criss-cross delivery on their spines in a staggered position.

For in-line operation with a Pony-5 Perfect Binder, a jogging unit and automatic transfer can be added. A side stitcher with two stitching heads with maximum stitching capacity of $\frac{1}{2}$ "– $\frac{3}{4}$ " can also be incorporated.

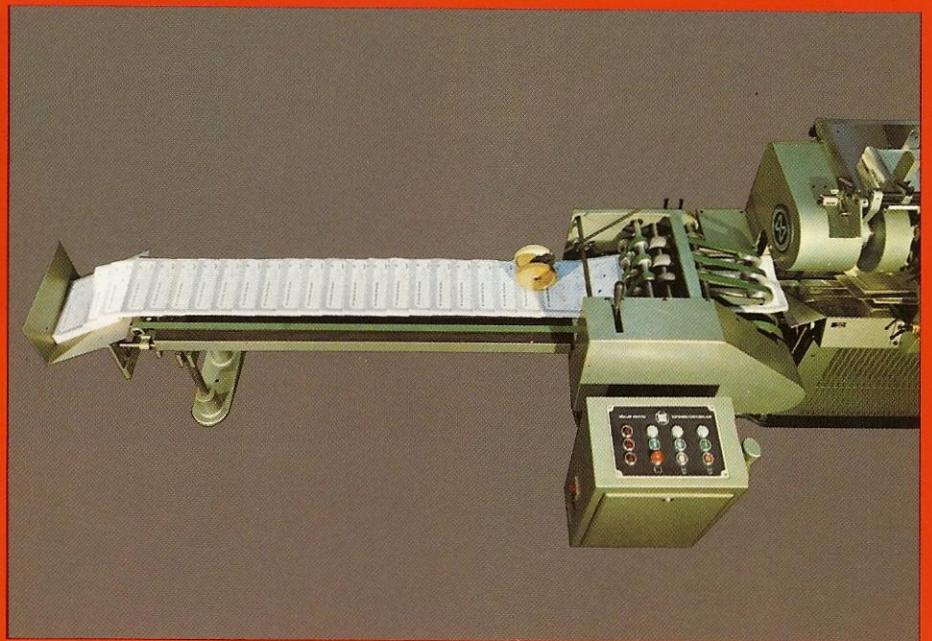
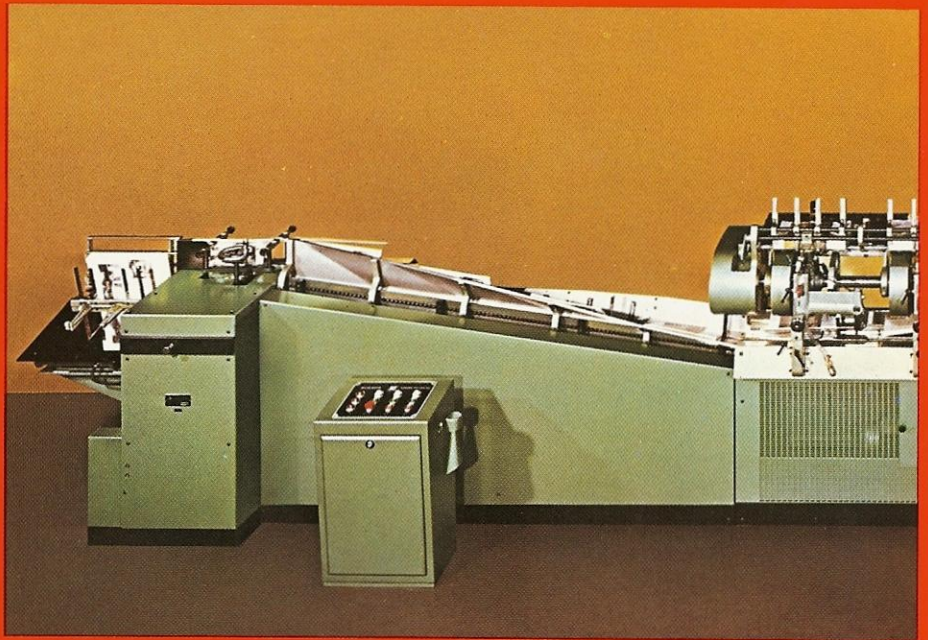

Belt Delivery (Combi-Delivery)

The belt delivery is a simple, versatile delivery for all types of work. Books are delivered on a conveyor belt one by one or shingled.

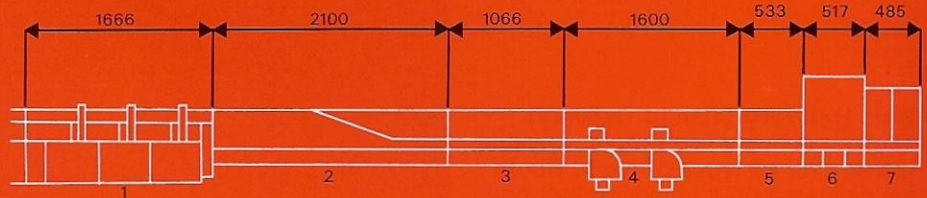
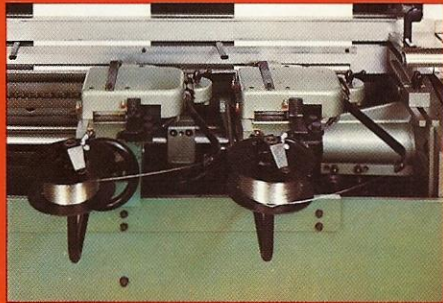
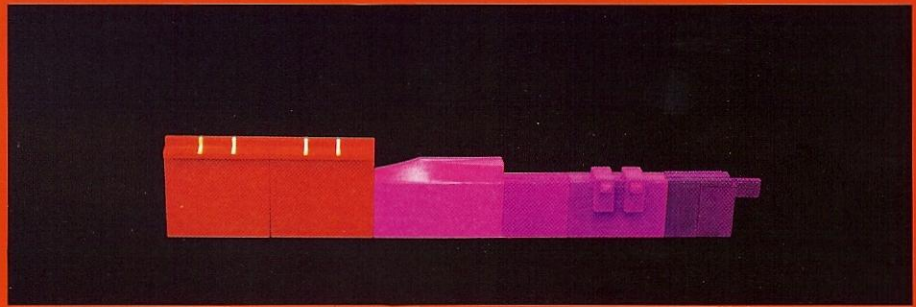
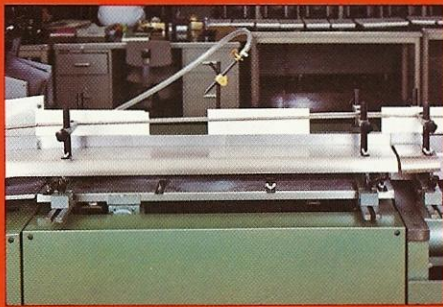

Gathering Machine 201 with Side Stitcher and Criss-Cross Delivery

This line is designed for gathering of signatures and in-line side stitching of book blocks. The side stitching unit can be added later.

A maximum of 18 stations can be incorporated.

In the spiral raceway, signatures are turned up on their spines. Books travel through the jogging unit prior to side stitching. The side stitcher is equipped with 2 stitching heads and 2 formers. The stitching heads travel with the book and have a maximum stitching capacity of $\frac{1}{2}$ "- $\frac{3}{4}$ ". Heads are individually adjustable. The maximum distance between stitches is $1\frac{3}{4}$ ".

The stitching unit can be disengaged at any time.

Side stitched books are delivered by the criss-cross delivery in a staggered position.

- 1 Gathering Machine
- 2 Spiral raceway
- 3 Jogging unit
- 4 Side stitcher
- 5 Spacer element
- 6 Drive unit
- 7 Criss-cross delivery

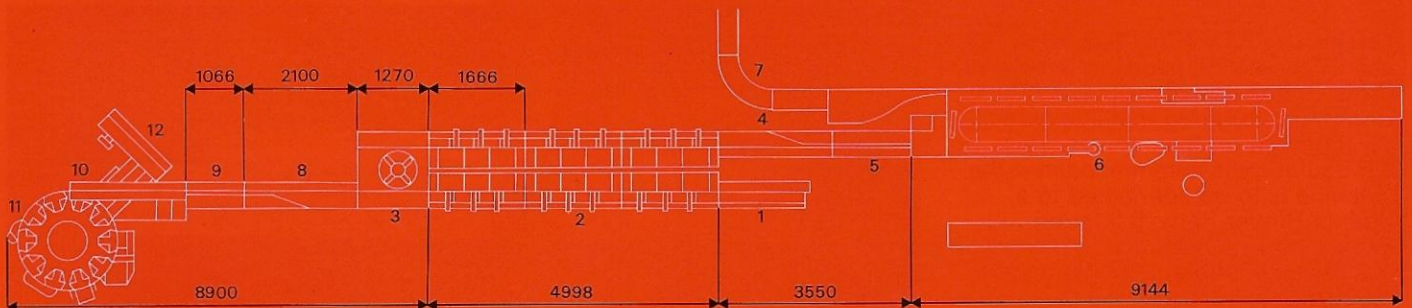
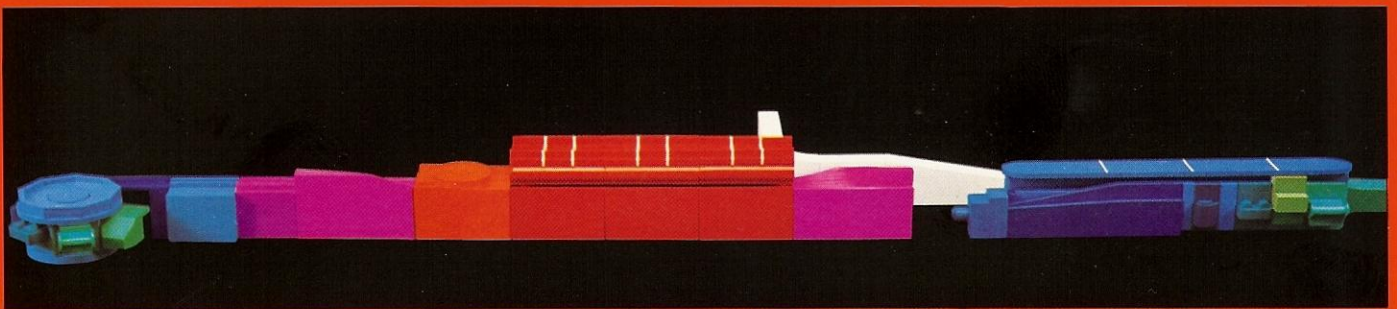

Gathering Machine 201 with U-turn connected to two Perfect Binders, Model RB-5 and NB-2S

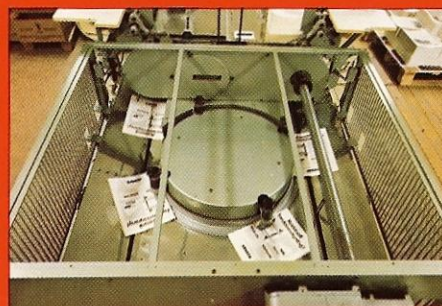

- 1 Hand feeding station with chain tensioner
- 2 Gathering Machine 201
- 3 U-turn
- 4 Spiral raceway
- 5 Height compensating unit
- 6 Modular Binder Model NB-2S
- 7 Conveyors to 3-knife trimmer
- 8 Spiral raceway
- 9 Jogging unit
- 10 Transfer unit
- 11 Rotorbinder RB-5
- 12 Batch/Stacker delivery, 63" long

A U-turn is recommended if space is limited.

Operating possibilities:

1. Separate operation of the Rotorbinder RB-5 and the Modular Binder NB-2S, for simultaneous production of identical or two different products. The U-turn is disengaged in this mode of operation.

2. Single production on the Modular Binder NB-2S for bulky books (e.g. for jobs with more than nine signatures). The Rotorbinder RB-5 can be operated separately by feeding pregathered or sewn book sections manually into the clamps.
3. For gathering only, the Rotorbinder RB-5 is disconnected from the Gathering Machine 201. Gathered book blocks are delivered into the criss-cross delivery on their spines and in a staggered position. Simultaneously, the Modular Binder can be operated with a limited number of gathering stations for perfect binding.

The Building Block Principle for gathering without perfect binding

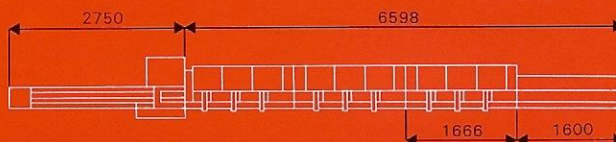

Gathering Machine 201 with belt delivery

Books are delivered on a conveyor belt one by one or shingled. A maximum of 30 stations can be incorporated.

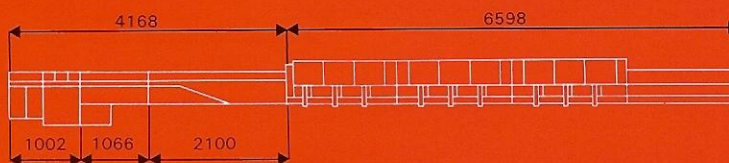
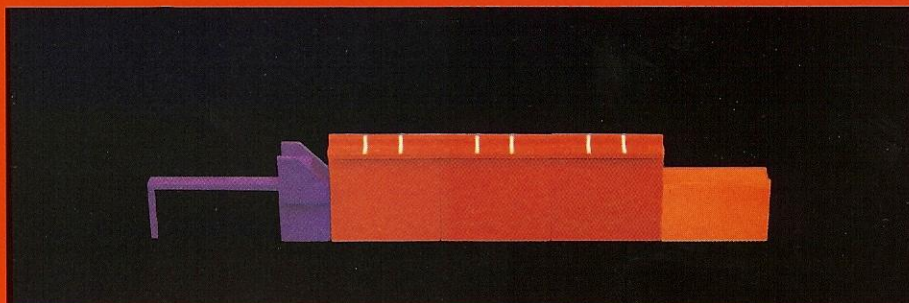

Gathering Machine 201 with spiral raceway, jogging unit and criss-cross delivery

Books are delivered in a staggered position and on their spines. This configuration is recommended if the machine is to be connected to a Perfect Binder Pony-5 later on. Expansion to a maximum of 30 stations is possible. Maximum speed, 4,500/hr.

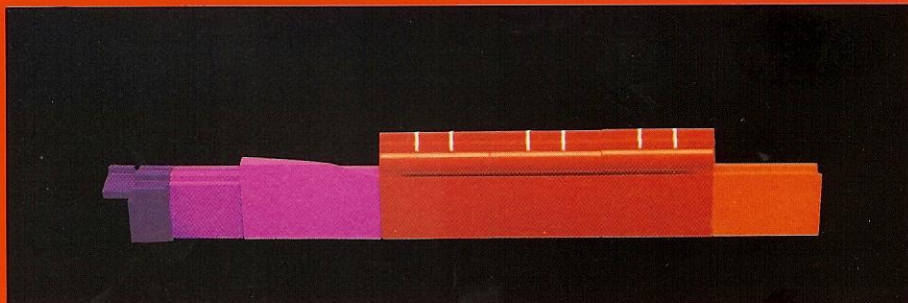

The Building Block Principle for gathering and in-line perfect binding

Perfect Binding Line Pony-5 consisting of Gathering Machine 201, U-turn, criss-cross delivery and Perfect Binder Pony-5

Operating possibilities:

1. Perfect binding line with U-turn and gathering machine with up to 24 stations.
2. Gathering only, on gathering machine with U-turn and criss-cross delivery.
3. Hand feeding of Perfect Binder Pony-5, equipped with separate drive.

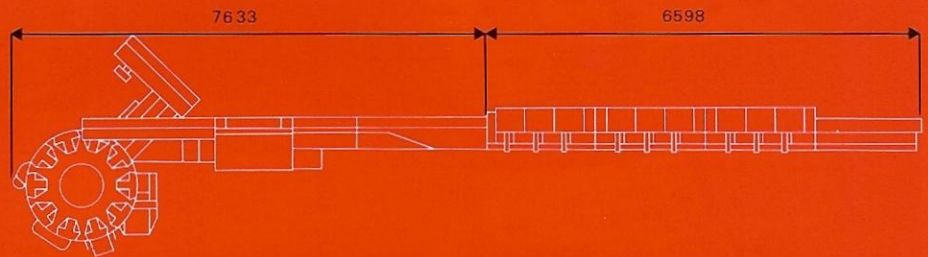
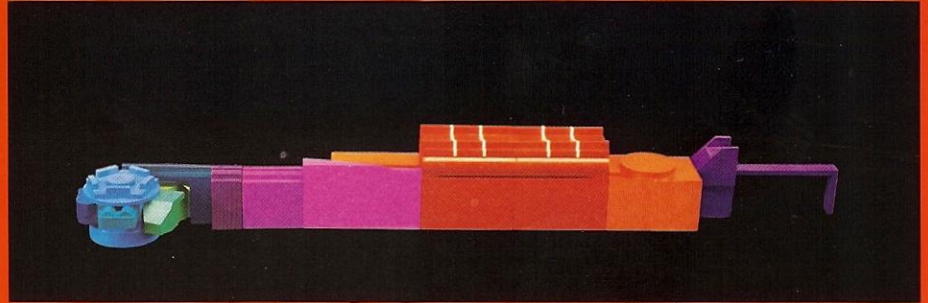
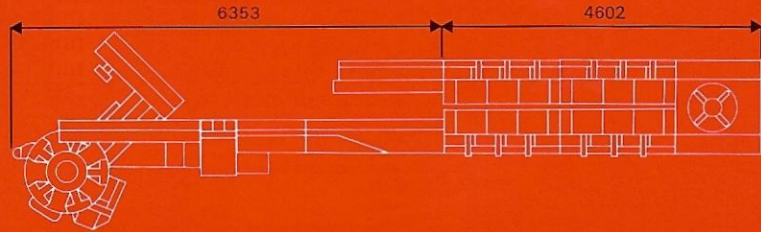

Perfect Binding Line Rotor-binder RB-5, consisting of Gathering Machine 201, spiral raceway, jogging unit, drive with separating clutch, criss-cross delivery and transfer to perfect binder

Operating possibilities:

1. In-line gathering and perfect binding.
2. Gathering only. Gathered book blocks are delivered into a criss-cross delivery.
3. Hand feeding of Perfect Binder RB-5.

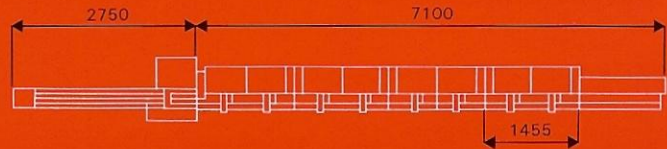
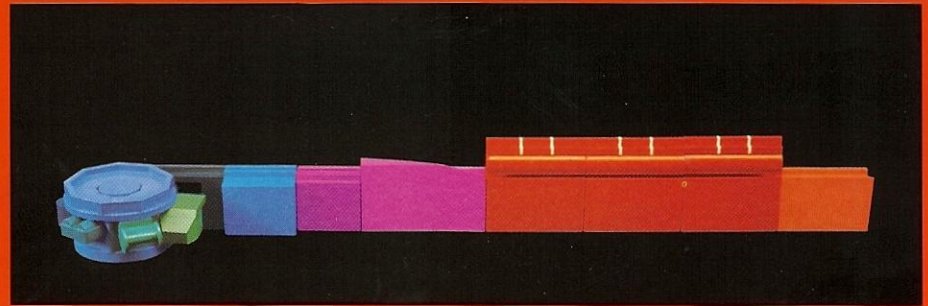

Calendar Gathering Machine 273

Two station elements with miss and double sheet detector on each pocket, a warning light per element, and hand station with chain tensioner. This machine is equipped with a belt delivery. A maximum of 14 stations can be incorporated.

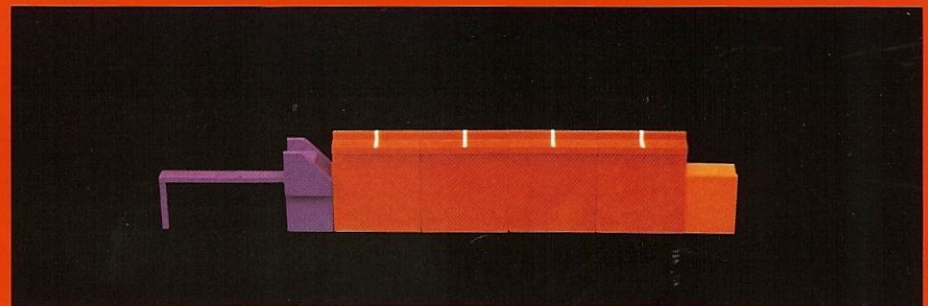

Gathering Machine 201

Book sizes	max. 450×320 mm	17 ³ / ₄ " × 12 ⁵ / ₈ "
	min. 140×100 mm	5 ¹ / ₂ " × 4"
Small size kit	min. 105×100 mm	4 ¹ / ₈ " × 4"
Book block thickness	max. 60 mm	2 ³ / ₈ "
Power consumption	approx. 4 KW per 3-station element approx. 1.3 KW for each additional element	
Speed	max. 4,500–5,000 per hour, depending on type of delivery unit	

Perfect Binding Line Pony-5/201

Book sizes	max. 350×270×40 mm	13 ³ / ₄ " × 10 ⁵ / ₈ " × 1 ¹ / ₂ "
	min. 140×100× 3 mm	5 ¹ / ₂ " × 4" × 1 ¹ / ₈ "
Small size kit	min. 120×100× 3 mm	4 ³ / ₄ " × 4" × 1 ¹ / ₈ "
Speed	max. 2,500/hr.	

Perfect Binding Line RB-5/201

Book sizes	max. 410×280×55 mm	16 ¹ / ₈ " × 11" × 2 ¹ / ₈ "
	min. 140×100× 3 mm	5 ¹ / ₂ " × 4" × 1 ¹ / ₈ "
Small size kit	min. 120×100× 3 mm	4 ³ / ₄ " × 4" × 1 ¹ / ₈ "
Speed	max. 5,000/hr.	

Calendar Gathering Machine 273

Sizes	max. 560×400 mm	22" × 15 ³ / ₄ "
	min. 180×180 mm	7 ¹ / ₈ " × 7 ¹ / ₈ "
Book block thickness	max. 60 mm	2 ³ / ₈ "
Speed	max. 5,000/hr.	

Design, specifications and measurements subject to change.

MÜLLER MARTINI