

Universal Folding Carton Packer JAPACK 40-2

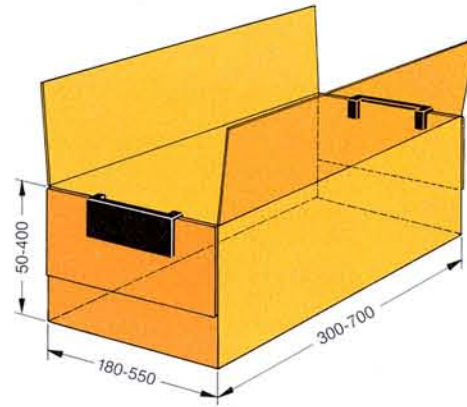

Shipping cases:

of rigid corrugated board, solid board or other material, with glued or unglued base, with and without cover panels.



JAGENBERG AG
Jagenbergstrasse 1
D-41468 Neuss
Postfach 101123
D-40002 Düsseldorf
Telephone (2131) 99-01
Telefax (2131) 99-2900
Telex 8517002

JAPACK 40-2

Universal Folding Carton Packer

Packing scheme:

1-row/1-layer up to 4-row/4-layer

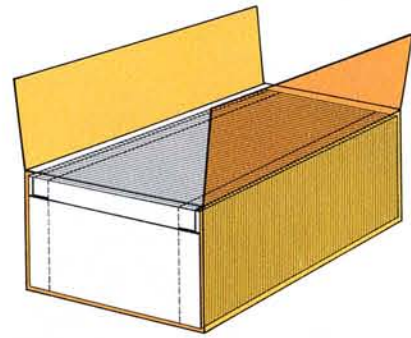

Packed on creaselines

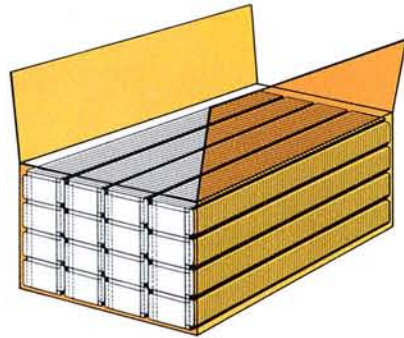

Packed on closure flaps

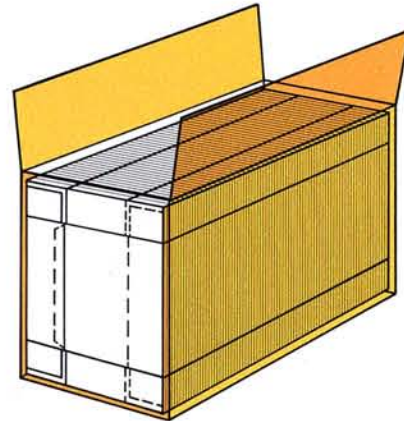

Range of application:

straight-line folding cartons and collapsible boxes of folding box board 200-600 g/m² (40-100 lbs./MSF).

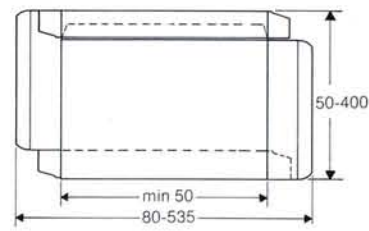

Straight-line folding carton

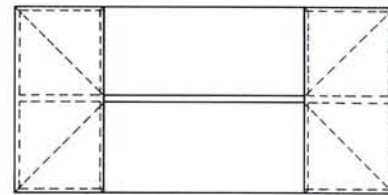

4-corner glued collapsible box

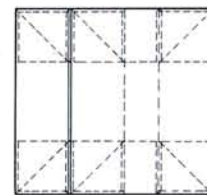

6-corner glued collapsible box

Output: Matches that of the folding carton gluer to which machine is connected (belt speed up to 400 m/min = 1,300 ft./min.).

Machine dimensions:

Length 4,380 mm 14'5"	Width 2,930 mm 9'8"	Height 2,150 mm 7'1"	Weight: 23,000 N (2.3 t/5,100 lbs.), net Seaworthy packing: 22 cbm/770 cu. ft.
-----------------------------	---------------------------	----------------------------	---

Patents: In all major industrial countries. All data represents non-binding guideline values. We reserve the right to make technical alterations at any time without special notice. Further details about the JAPACK 40-2 as well as about the other machines included in our manufacturing programme can be provided on request.

Subject to alterations
Printed in Germany
OMD IV 1.02.92137-04



Automatic packing of runs from 50,000 cartons upwards

With manual take-off and packing, modern high-speed folding carton gluers frequently cannot be run at full capacity. In many cases, automatic packing doubles the output.

The JAPACK 40-2 packs in multiple rows and multiple layers, making the corrugated shipping case economical even for small and medium-sized cartons.

Short makeready times make packing of medium and small carton lots economical.

Personnel costs become markedly lower through the new system.

All these features combine to reduce the unit cost per carton by up to one-third.

The JAPACK 40-2

- is used for runs of 50,000 cartons and upwards
- permits 40–50% faster gluing, in some cases even 120% faster (figures based on field experience)
- saves up to 2 or 3 operators, because often only one operator is required
- lowers unit cost per carton by up to 30%
- packs up to 4 layers and 4 rows
- packs on crease lines or on closure flaps
- has a makeready time averaging 10–15 minutes
- is easily moved around – can be combined with various gluers as required
- fits on most makes of folding carton gluers
- eases physical labour

Machine costs are fully compensated when machine is used 60% of the time and one operator is saved.

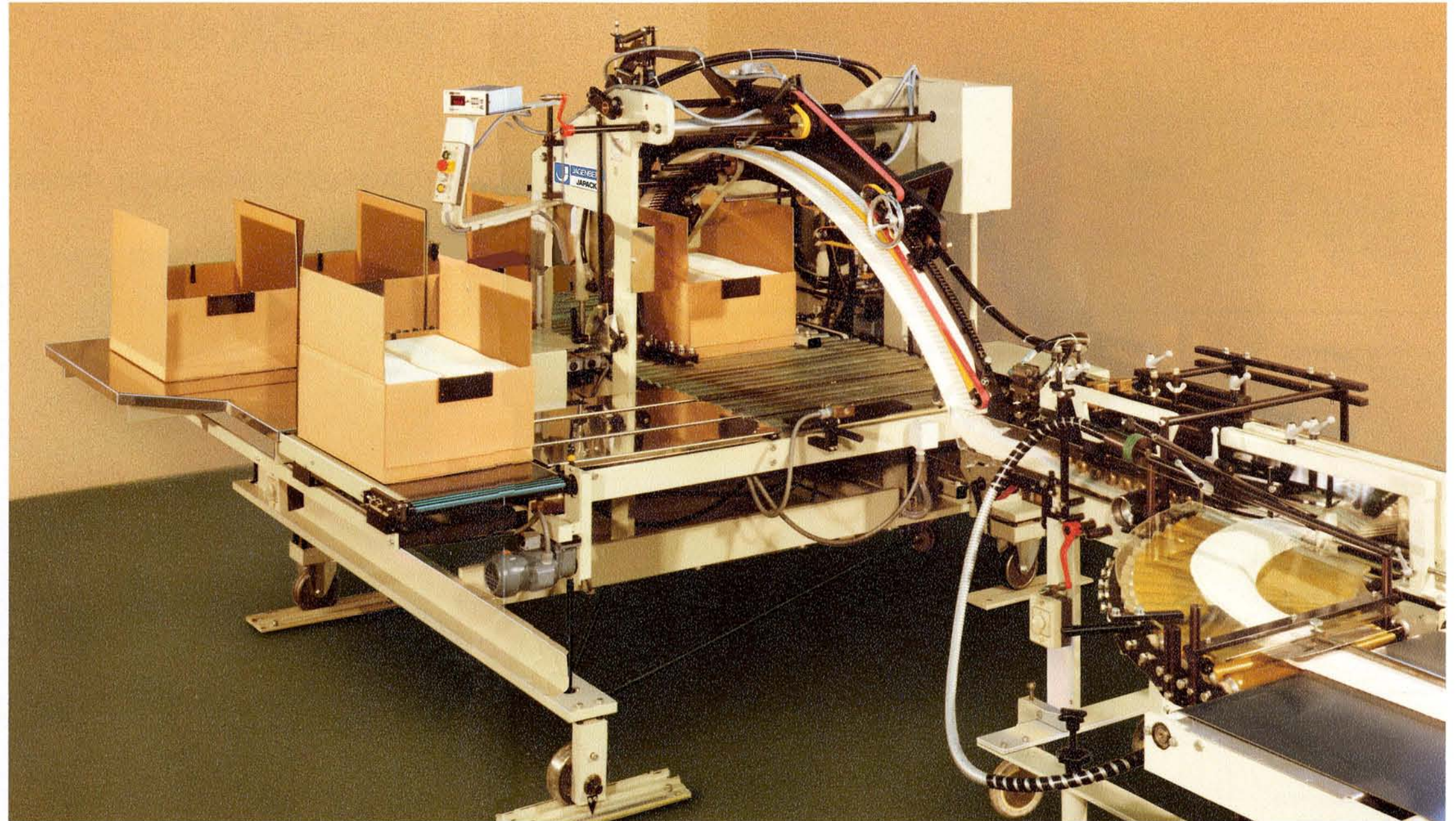

**Take Advantage of this Opportunity!
Buy Efficiency – Buy JAPACK!**

