



Why buy from IBIS?

Because we will give you real advantage over your competitors by:

Reducing your production costs

- In-line or off-line operation.
- Up to 2440 pages/min throughput (up to 12,000 books/hr output).
- Stitched *and* glued books up to 60mm (2.36") thick from the same machine.
- Low running costs.

Enhancing your book quality

- Individual sheet folding for better lay-flat of saddle-bound books up to 200 pages.
- ISG cold gluing available for increased strength and improved lay-flat.
- Three-side trimming.
- Square-backed perfect bound books (SB-4 only) with 4-scored covers and wheel side-glue.
- Bar code sheet tracking and auto-reject for guaranteed book page integrity.

Smart-binder output



- Saddle-stitched books up to 10mm (0.4") thick.



- Saddle-glued books up to 10mm (0.4") thick – ISG Cold Glue.



- Square-back books made with cold & hot glue up to 60mm (2.36") thick.

Sprint-binder output



- Square-back perfect bound books up to 60mm (2.36") thick – hot-melt or PUR glue only.

Increasing your up-time

- Very robust, high quality machine construction for 7 x 24 hr, reliable operation.
- Easy and quick to maintain.
- Focus on operator and maintenance training.

Providing support and customisation

- Highly skilled specialist field engineers.
- Technical support by phone and email.
- First level on-site support from digital printer vendors.
- Large range of special options and added value features.
- Special engineering to customise systems to your specific needs.



Product Range

Smart-binder	Model	Max. Input Speed (A4 pages/min)	Wire Stitching	ISG Cold gluing	ISG Cold glue & Hot melt glue	Max book thickness
For saddle stitched, saddle glued and/or perfect bound books	SB-1	400	✓	x	x	10mm (0.4")
	SB-1G	400	✓	✓	x	10mm (0.4")
	SB-1G4	400	✓	✓	✓	60mm (2.36")
	SB-2	1200 (or 2400 with extra folder)	✓	x	x	10mm (0.4")
	SB-3		✓	✓	x	10mm (0.4")
	SB-4		✓	✓	✓	60mm (2.36")
	SB-5		✓	✓	✓	60mm (2.36")

Sprint-binder	Model	Throughput	Number of Clamps	Gluing Options	Max book thickness
For perfect bound books only	PB-600C	400 pages/min (input)	1	hot melt or PUR	60mm (2.36")
	PB-600S	400 books/hr	1	hot melt or PUR	60mm (2.36")
	PB-2000J	1500 book/hr	4	hot melt or PUR	40mm (1.6")

Features

- In-line connection with highest speed digital printers, or off-line operation from a high speed sheet feeder, or roll unwinder.
- Individual sheet folding for optimum saddle-bound book quality.
- Cover and Insert sheet feeding.
- Bar code tracking of all sheets and auto-rejection of bad books, to ensure integrity.
- Book page count variable on the run (Smart-binder and PB-600).
- Three-knife trimming with optional centre-knife for Smart-binder.
- Heavy duty construction for 24 x 7 operation.
- Easy-to-use touch-screen controls.
- Complete range of book format sizes.
- Optional sheet dynamic micro-perforation and hole punching for Smart-binder.

Specifications	SB-1	SB-2	SB-3	SB-4	PB-600C	PB-600S	PB-2000J
Max. input speed	250 x A4 pages/min	1200 A4 pages/min or 2400 with extra folder			400 pages/min	400 piles/hr	2400 pages/min
Off-line sheet feeding speed	62 x A3 sheets/min	300 x A3 sheets/min					
Max. output speed (books/hour)	6,000 12,000 (with trimmer centre knife)				400	1500	
Max. book thickness	10mm (0.4")			60mm (2.36")		40mm (1.57")	
Min. book thickness	8 pages (2 sheets)				2mm (.08")		
Max. book size	320 (spine) x 225 mm (12.6 x 8.9")						320 (spine) x 280 mm (12.6 x 11")
Min. book size	97 (spine) x 119 mm (with centre knife) (3.8 x 4.7")			210 (spine) x 119mm (8.3 x 4.7")		120 (spine) x 140 mm (4.72 x 5.5")	
Min. sheet weight	50 grams /square metre (40 grams with extra folder). 13.4lbs bond (10.6lbs with extra folder)						
Stitching heads	Max. 4 heads - flat or loop stitch with 14mm (0.55") crown length. Round section wire 0.4 - 0.6mm (16 - 24 thou) diameter				N/A		
Gluing system	Not available	ISG cold glue		ISG cold, + hot melt glue	hot melt EVA or PUR		
Trim	Front knife: up to 27mm (1.06") Side knives: up to 20mm (0.8")				Optional		
Maintenance	Minimal maintenance requirements						
Operator interface	Graphical touch screen with multi-languages for system set-up, operation, and operator feedback.						

Smart-binder Products



**NEW
'PLUS'
Model**

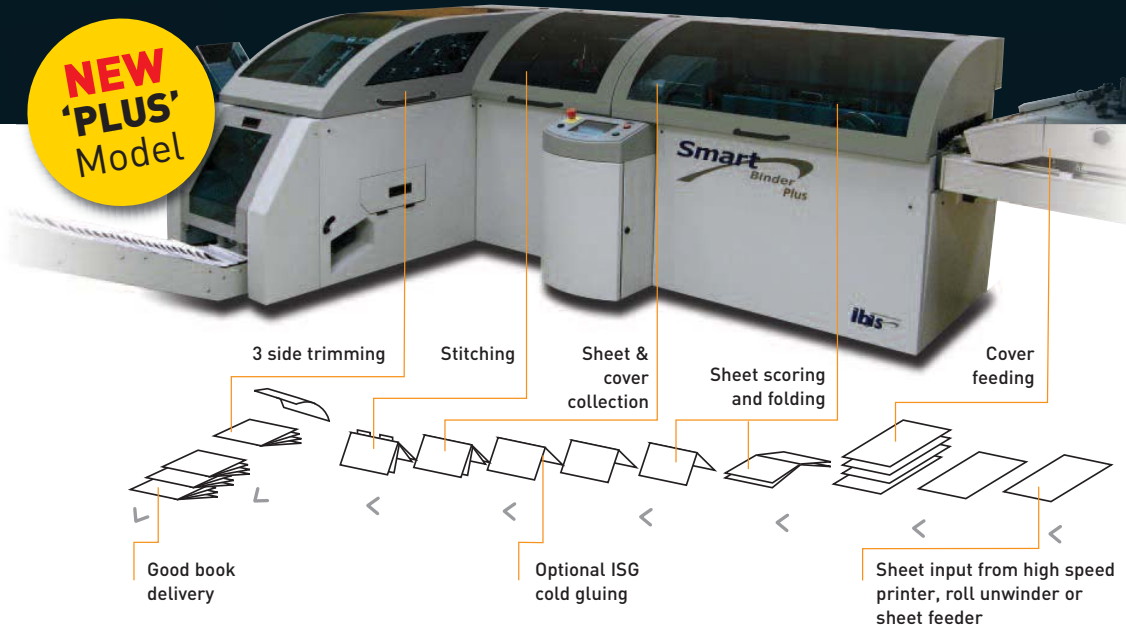

Smart-binder system

The Smart-binder systems are all based upon IBIS's unique saddle-stitcher which was launched in 2004. Models SB-1 and SB-2 produce wire-stitched books only. Models SB-3 and SB-4 also include ISG cold gluing.

The Smart-binder models SB-4 and SB-5 include an additional perfect binder for thicker 'perfect-bound' book production in addition to saddle-bound books. The SB-4 includes a perfect binder directly after the saddle-stitcher. The SB-5 includes a perfect binder which is separate from the saddle stitcher.

Smart-binder SB-1, SB-2 and SB-3

- For high-quality saddle-bound booklets.
- 'On-the-run' re-loading of cover sheets.
- SB-3 includes ISG cold gluing module to produce saddle-glued books.
- Upgradable to SB-4 or SB-5.

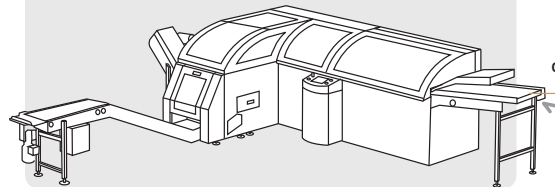

Sheet input from high speed printer, roll unwinder or sheet feeder

Smart-binder SB-4 One-stop-shop

The ultimate, flexible book-finishing system

- For saddle-stitched booklets, saddle-bound ISG cold-glued booklets and perfect-bound books made from ISG-glued signatures.
- In-line thick-book trimming.

Sprint-binder (600S or 2000J)
Perfect-binder

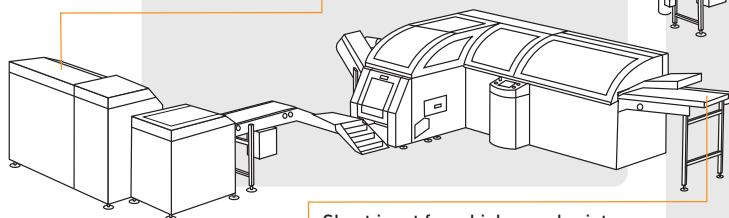

Sheet input from high speed printer, roll unwinder or sheet feeder

Smart-binder SB-5 One-stop-shop

- For saddle-stitched booklets, saddle-bound ISG cold-glued booklets and conventional Perfect-bound books.
- In line thick-book trimming.

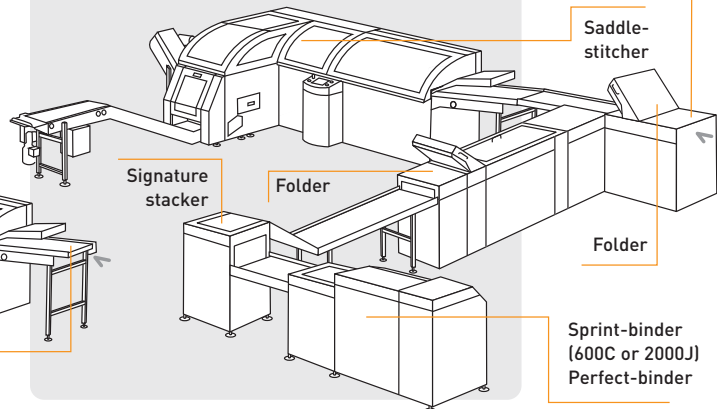

Sheet input from high speed printer, roll unwinder or sheet feeder

Saddle-stitcher

Signature stacker

Folder

Folder

Sprint-binder (600C or 2000J)
Perfect-binder