

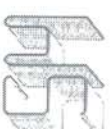





WP 800/1100/1400 matic



2.10

Technical data

-  Carton blank
-  Film
-  Feed gate
-  Left
-  Chain lug

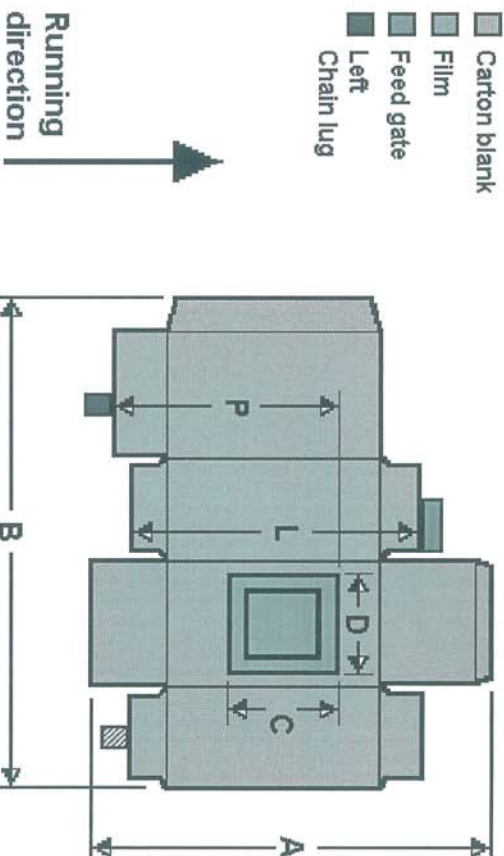

Machine type	1-run operation			2-run operation			
	WP800 WP800/D	WP1100 WP1100/D	WP1400 WP1400/D	WP800/D	WP1100/D	WP1400/D	
Format range							
A min	100	100	100	100	100	100	
A max	1020	1020	1020	1020	1020	1020	
B min	80	80	80	80	80	80	
B max	800	1100	1400	360	510	660	
C min	60	60	60	60	60	60	
C max	720	720	720	720	720	720	
D min	30	30	30	30	30	30	
D max	540	840	1018	230	380	465	
Power							
Length A under 350 mm	item / Minute	495	495	495	990	990	990
Length A under 560mm	item / Minute	330	330	330	660	660	660
Length A over 560 mm	item/ Minute	165	165	165	330	330	330
Measurements							
Length	mm	5660	5660	5660	5660	5660	5660
Width	mm	1600	1900	2200	1600	1900	2200

Technical data are limiting values and depend on material quality and blank shapes. Extreme values within one blank are not possible. Subject to changes.