



Corona Perfect Binder

Specifications

Corona	C12	C13	C15	C18
Mechanical speed, c/hr.	12,000	13,500	15,000	18,000
Clamp pitch	24"	18"	24"	18"
Sizes spine length	max. 510 mm (20 ¹ / ₈ ") min. 140 mm (5 ¹ / ₂ ")	360 mm (14 ¹ / ₈ ")	510 mm (20 ¹ / ₈ ")	360 mm (14 ¹ / ₈ ")
book width	max. 310 mm (12 ¹ / ₄ ") min. 100 mm (4")			
book thickness	max. 60 mm (2 ³ / ₈ ") min. 2 mm (5 ⁵ / ₆₄ ")	optional 80 mm (3 ¹ / ₈ ")		
Clamp opening	max. 80 mm (3 ¹ / ₈ ")	optional 107 mm (4 ³ / ₁₆ ")		
Book hang-out	max. 17 mm (1 ¹ / ₁₆ ") min. 7 mm (1 ¹ / ₄ ")			
Cover width	max. 642 mm (25 ¹ / ₄ ") min. 202 mm (8")			
Premelter, free-standing	for spine gluing unit	capacity power requirement	80 liter (21 US gal) 11 kW	160 liter (42 US gal) 21 kW
	for side gluing unit	capacity power requirement	18 liter (4,8 US gal) 6 kW	30 liter (7,9 US gal) 7 kW
Air requirements	Per premelter for side gluing	compressed air	5 Nm ³ /hr @ 6 bar (3 cfm @ 87 psi)	
	Per cold glue spine gluing unit		2 Nm ³ /hr @ 6 bar (1 cfm @ 87 psi)	
	cover feeder	blow air	40 Nm ³ /hr 0,6 bar (21 ft ³ /min @ 8,7 psi)	
		vacuum	20 Nm ³ /hr 60% (12 ft ³ /min @ 60%)	
		compressed air	36 Nm ³ /hr 6 bar (21 ft ³ /min @ 87 psi)	
Exhaust	milling station	air consumption	1500 m ³ /hr (880 cfm)	
		static pressure	min. 4 ³ / ₄ " WC (120 mm)	
	spine preparation	air consumption	1000 m ³ /hr (590 cfm)	
	per exhaust manifold	static pressure	min. 4 ³ / ₄ " WC (120 mm)	
	glue station/IR-dryer	air consumption	1200 m ³ /hr (710 cfm)	
	exhaust manifold	static pressure	min. 0,6" WC (15 mm)	

Other sizes on request.
Design, specifications and measurements
subject to change.

Corona C 12/26 with Gathering Machine Model 3691

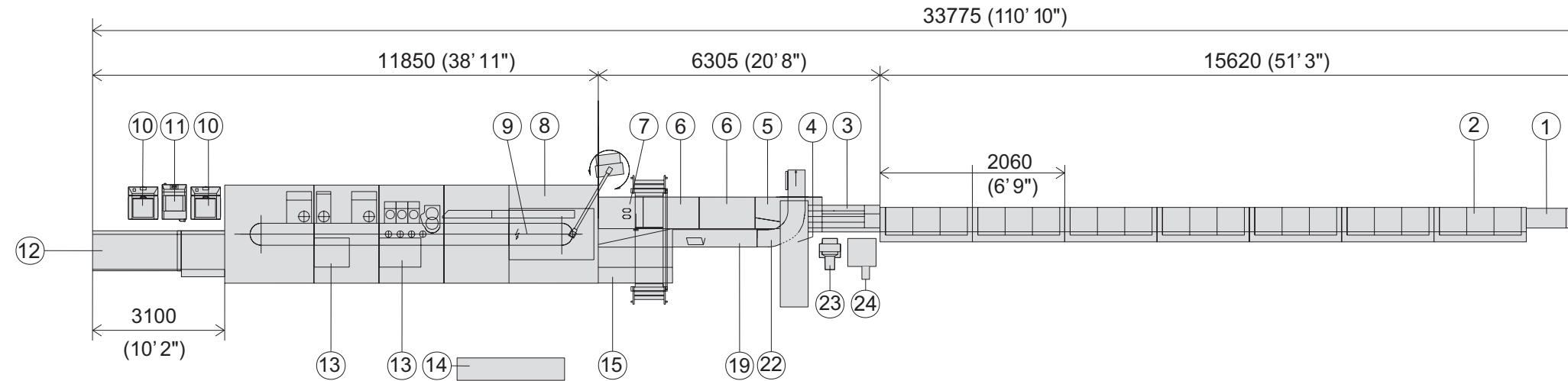

- | | | | |
|------------------------|------------------------------|---|----------------------|
| ① Tensioning unit | ⑦ Separating unit | ⑬ Nipper | ⑲ Straight conveyor |
| ② Gathering machine | ⑧ Corona perfect binder | ⑭ Operator console for gathering machine | ⑳ Bi-level conveyor |
| ③ Reject gate | ⑨ Operator console | ⑮ Laydown delivery | ㉑ Shingling conveyor |
| ④ Escape delivery belt | ⑩ Premelter for spine gluing | ⑯ Vertical gate | ㉒ Power turn |
| ⑤ Spiral raceway | ⑪ Premelter for side gluing | ⑰ Escape delivery | ㉓ Blower |
| ⑥ Jogging unit | ⑫ Cover feeder | ⑱ Straight conveyor with accelerator roller | ㉔ Vacuum pump |

Corona C 18/41 with Gathering Machine Model 3681

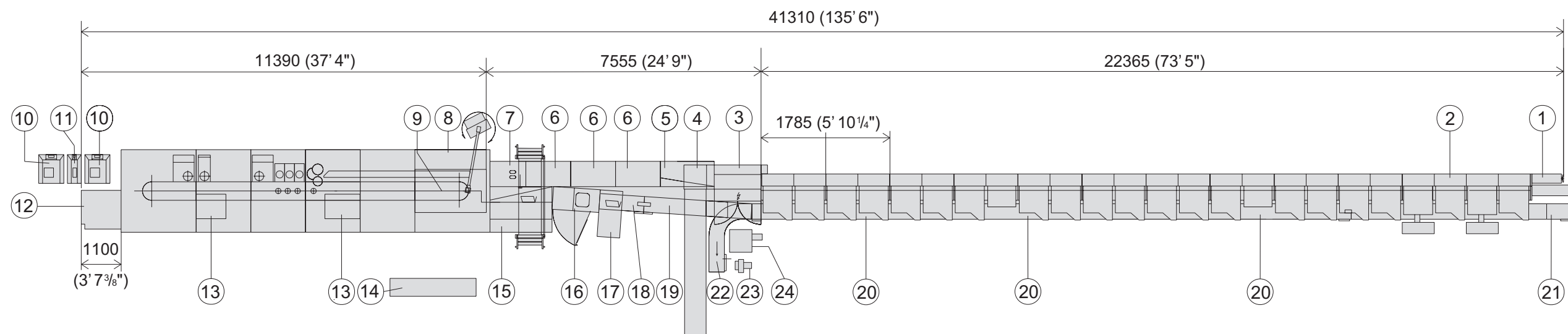

Sizes

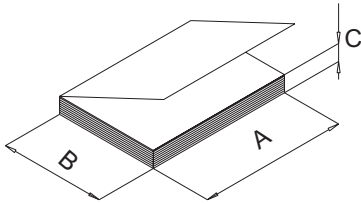

24"

	max.	min.
A	510 mm (20 1/8)	140 mm (5 1/2)
B	310 mm (12 1/4)	100 mm (4)
C	60 mm (2 3/8)	2 mm (5/64)

18"

	max.	min.
A	360 mm (14 1/8)	140 mm (5 1/2)
B	310 mm (12 1/4)	100 mm (4)
C	60 mm (2 3/8)	2 mm (5/64)



Oblong sizes that cannot be processed



Acceptable size range depending on machine settings and signature types

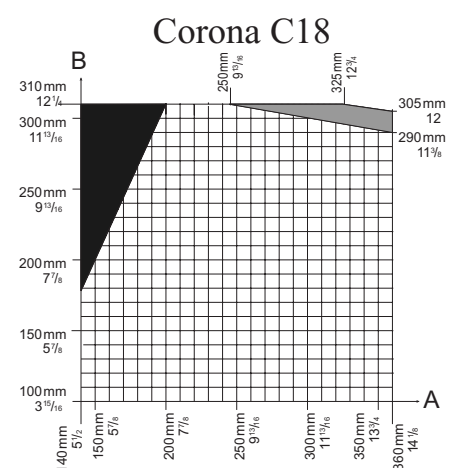
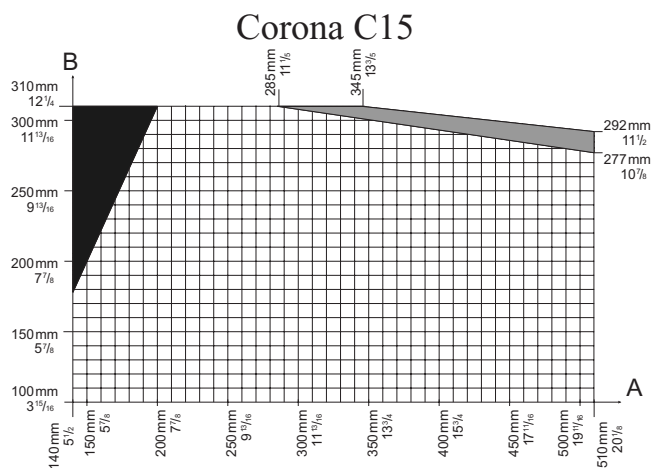
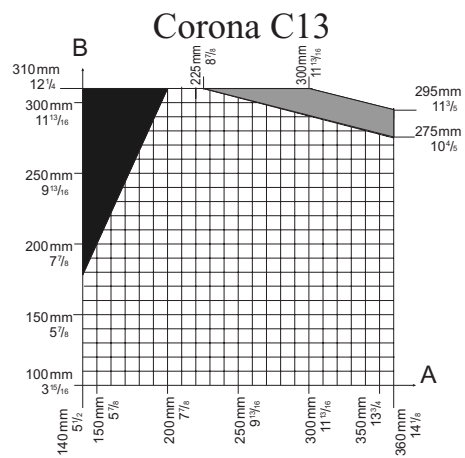
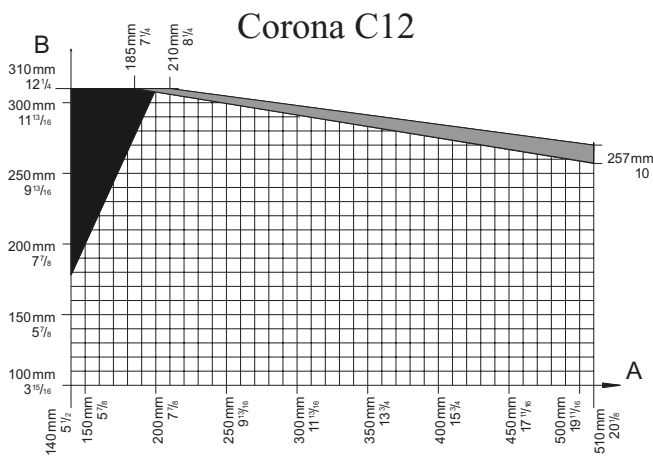

MÜLLER MARTINI

Müller Martini Marketing AG

Untere Brühlstrasse 13
CH-4800 Zofingen, Switzerland

Phone ++41-62/745 45 75

Fax ++41-62/751 55 50

E-mail info@mullermartini.com

Internet <http://www.mullermartini.com>