

800 / 1100

SMARTFOLD ULTRA X

FOLDER-GLUERS



www.dgm-global.com

ADGM CARTON
CONVERTING
EQUIPMENT

SMARTFOLD ULTRA X Folder-gluer

800 / 1100

EQUIPPED WITH ADVANCED STATE OF THE ART TECHNOLOGIES FOR FAST JOB CHANGEOVER.

SMARTFOLD ULTRA X folder gluer models are equipped with advanced state of the art technologies for fast job changeover, especially focussed on multi-type work capabilities with medium-long to shorter run lengths in mind. Speed up to 500 meters/min.

Motorized carriers, full and sectional job/memory recall, extended pre-folding section up to 3 meters in total length. Lifting upper carrier on pre-folding section. New "universal multi-function section" with integrated "bump & turn" allows to turn cartons 90° and its alignment. Pre-breakers device by outer belts on both sides. New servo drives technologies, extra length crash lock bottom section. Extra folding & closing section with collapsible central carrier, able to produce complex carton structures, straight line, lock bottom, 4 & 6 corner cartons and more. DGM has been committed to offer the industry an affordable, cost effective and complete state of the art solution for the folding and gluing needs of today's converter and market demands, one of the best cost/value/productivity equipment combination to be offered to the industry.



MODELS

SMARTFOLD ULTRAX 800 PC / 1100 PC
Suitable for straight-line, crash-lock bottom & double wall boxes.

SMARTFOLD ULTRA X 800 SL / 1100 SL
Suitable for straight-line, crash-lock bottom, double wall, 4 & 6 - corner boxes.

MATERIALS

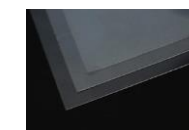

Plastic



Cartonboard



Corrugated board

BOXES

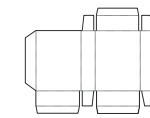

Straight line

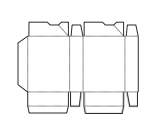

Lock - bottom box

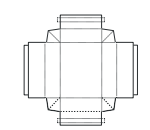

Double - wall Box

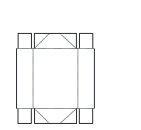

4 corner Box

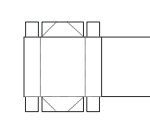

4 corner Box with Lid

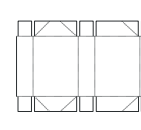

6 - corner box



COMPONENTS FOR ALL MODELS

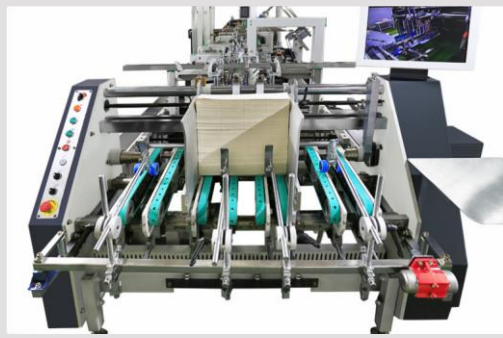

1

Feeder section

- Driven independently by servo motor.
- Friction feeder with 6/8 untimed feeding belts, 30 mm width.
- Electronic pile vibrator.
- Lateral feed gates fully adjustable to the width of the blank.
- Three adjustable front feed knives with carton spacing carriers (bogies).

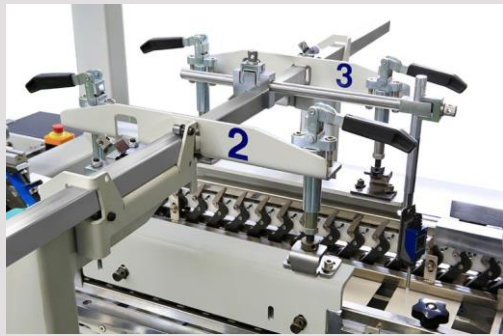

2

Side register section

- Driven independently by servo motor.
- Independent section with an unparallel lower carrier that guides the box to a parallel handrail that allows a perfect blank alignment.



3

Pre-folding section

- Driven independently by servo motor.
- Extra length pre-folding section, 3 meters long.
- Left hand glue flap pre-folder up to 180°.
- Third crease line pre-folder up to 135°.
- 1st and 3rd crease openers.
- Three upper and lower carriers along full section.



4

Multi-function section

- Driven independently by servo motor.
- Extra length crash lock bottom section.
- 3 sets of upper and lower transfer carriers along the section.
- Complete set of folding hooks and helixes to fold the front flaps of the blank smooth and accurately.
- Set of accessories for "B" lock bottom.
- Integrated "bump & turn" allows to turn cartons 90° and its alignment.
- Pre-breakers device by outer belts on both sides.



5

Gluing unit

- One lower (left side) gluing tank.
- Easy to remove and clean.
- Standard 3 & 5 mm width glue disc.
- Optional electronic upper gluing system by guns, upon request.



6

Folding and closing section

- Driven independently by servo motor.
- Extra length folding & closing section, 4.5 meters long.
- Collapsible central carrier by pneumatic system, saving time for set-up and allows to run small boxes.
- Lifting central upper carrier by pneumatic system.
- Smooth and accurate folding of 2nd and 4th crease.
- Outer folding belts adjustable up to 180° with variable speed.
- Two upper & two lower carriers with 25 mm lower and 30 mm outer belts.
- Width-wise adjustable heavy-duty compression rollers (optional).
- Detectors of proximity between carriers to avoid damages when approaching.



7

Trombone section

- Driven independently by servo motor.
- Pneumatic box ejector, for quality control without interrupting the flow of boxes.
- Upper and lower drive mechanism for length adjustment.
- Equipped with automatic belt tension-adjusting system.
- Continuous and automatic box collection mechanism that ensures a neat transfer to the Press section, guaranteeing a well aligned flow.
- Electronic counter and "Kicker" for marking batches.
- Squaring device for crashlock bottom boxes.



8

Press section

- Independent motorized section by servo-motors.
- Manual and Automatic speed variation in coordination with a photocell.
- Upper section moves back and forward, allowing for different box length.
- 5.5 m total length with 3.1 m effective pressure length.
- Apron width 900 mm.
- Pneumatic pressure adjustment to avoid marks.
- Pneumatic squaring system with two motorized carriers with belts.
- Motorized device to move the sponge belt across the conveyor.



9

4 & 6 corner device

- Motorized and untimed electronic back folding system with intelligent servo motor technology. It allows accurate folding of all back flaps by mean of hooks installed in two independent shafts controlled electronically.

SMARTFOLD ULTRA X

800 / 1100

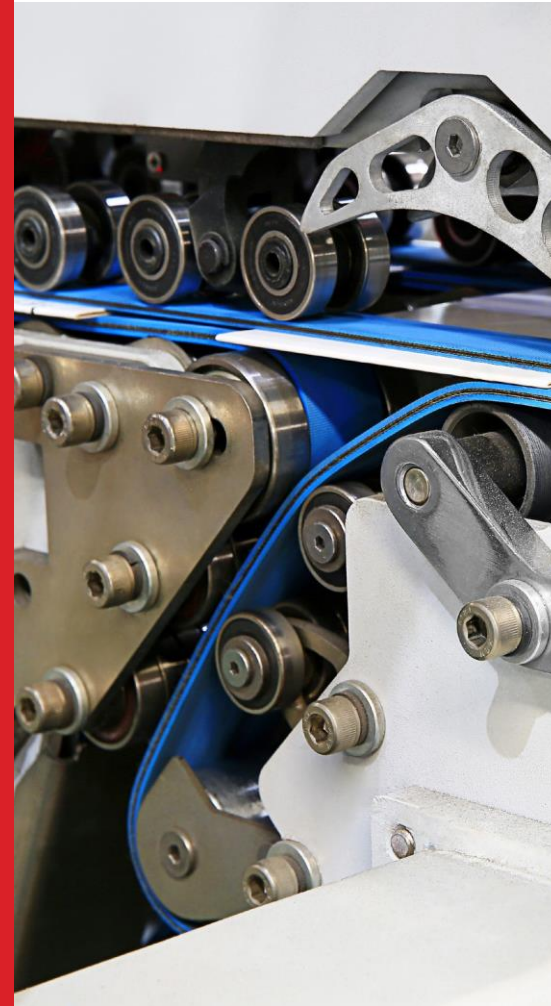

SPECIFICATIONS

SMARTFOLD ULTRA X	800	1100		
Processed materials				
Carton board max.	800 g/m ²	800 g/m ²		
Corrugated flute type	N, E & F	N, E & F		
Capability				
Speed max.	500 m/min	500 m/min		
Inching speed	30 m/min	20 m/min		
Thickness of folded box max.	20 mm	20 mm		
Blank width	800 mm	1100 mm		
Dimensions & weight				
	PC	SL	PC	SL
Length	18.45 m	18.45 m	18.45 m	18.45 m
Width	1.6 m	1.6 m	1.9 m	1.9 m
Height	1.9 m	1.9 m	1.9 m	1.9 m
Net Weight	12 Ton	12.2 Ton	12 Ton	12.2 Ton
Installation				
Electrical connected load	66 kW	66 kW	66 kW	66 kW
Compressed air	6 bar	6 bar	6 bar	6 bar
Air compressor capacity	10 m ³ /h	10 m ³ /h	10 m ³ /h	10 m ³ /h
Air tank capacity	60 L	60 L	60 L	60 L

SCHEME SMARTFOLD ULTRAX1100

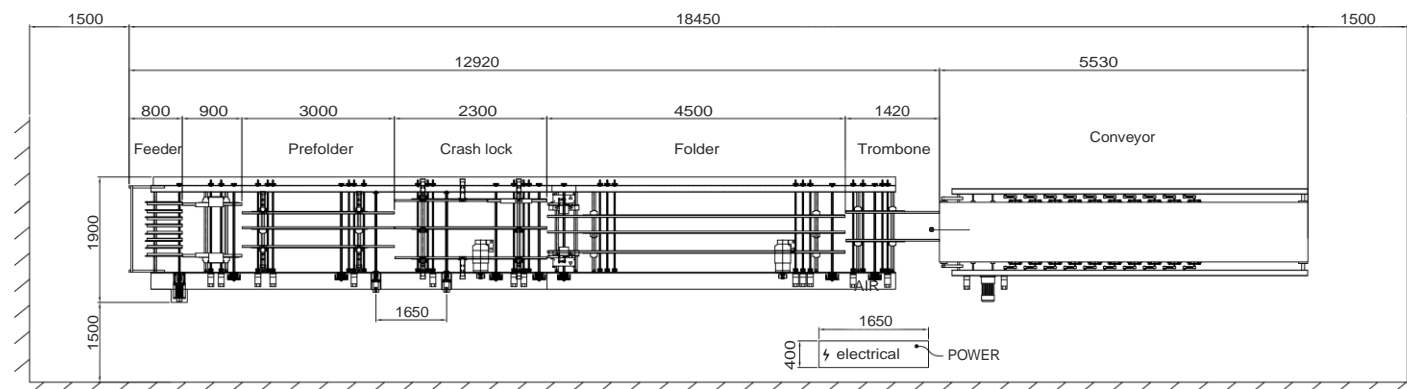

BOXES

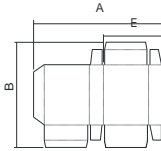
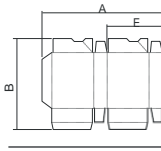
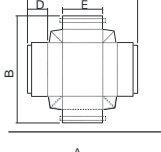
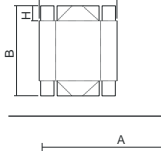
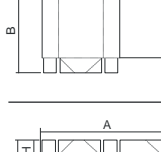
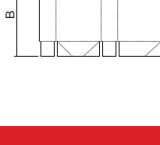
	800	1100
 Straight line	A: 150 - 800 mm B: 100 - 1100 mm E: 70 - 390mm	A: 195 - 1100 mm B: 100 - 1200 mm E: 90-540mm
 Lock - bottom	A: 150 - 800 mm B: 110-1100mm E: 70 - 390 mm	A: 195 - 1100 mm B: 110 - 1200 mm E: 90 - 540 mm
 Double - wall	A: 200 - 800 mm B: 100 - 1100 mm D: 30 - 150mm E: 80 - 680 mm	A: 240 - 1100 mm B: 100 - 1200 mm D: 30 - 150 mm E: 100 - 960mm
 4 - corner	A: 140 - 800 mm B: 140 - 1100 mm H: 25 - 150 mm	A: 160 - 1100 mm B: 140 - 1200 mm H: 25 - 150 mm
 4 - corner with Lid	A: 250 - 800 mm B: 140 - 1000 mm H: 25 - 150 mm	A: 270 - 1100mm B: 140 - 1100 mm H: 25 - 150 mm
 6 - corner	A: 250 - 800 mm B: 140 - 1000 mm H: 25 - 150 mm	A: 270 - 1100mm B: 140 - 1100 mm H: 25 - 150 mm

Huizhou De Gang Machinery Co., Ltd



USA & Canada exclusive distributor:

