

## **Merit S**

the three-knife trimmer with  
exclusive shear cutting action

**MÜLLER MARTINI**

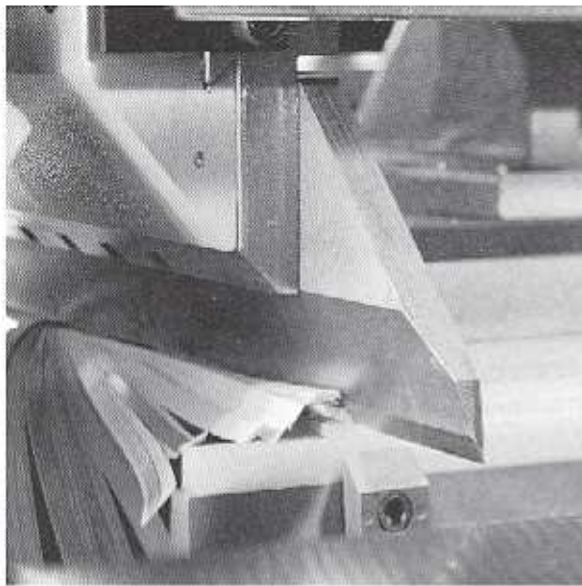



## Merit S Three-knife Trimmer

### Specifications

**Mechanical speed** 1000 to 4000 cycles per hour

**Speed of infeed conveyor** max. 7500 cycles per hour

#### Sizes

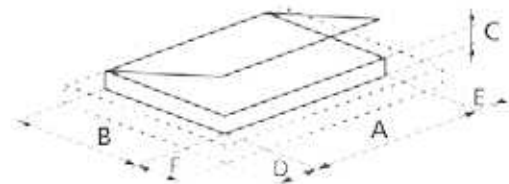

<b>untrimmed</b> (standard)	max. 384 mm (15 1/8" (A-D+E)) X 320 mm (12 5/8" (B+F))
	min. 140 mm (5 1/2" (A+D+E)) X 73 mm (2 7/8" (B+F))
Large size (option)	max. 445 mm (17 1/2" (A-D+E)) X 320 mm (12 5/8" (B+F))
Small size (option)	min. 104 mm (4 1/8" (A-D+E)) X 73 mm (2 7/8" (B+F))
<b>trimmed</b> (standard)	max. 304 mm (12" (A)) X 310 mm (12 3/16" (B))
	min. 136 mm (5 3/8" (A)) X 70 mm (2 3/4" (B))
Large size (option)	max. 434 mm (17" (A)) X 310 mm (12 3/16" (B))
Small size (option)	min. 100 mm (4" (A)) X 70 mm (2 3/4" (B))
<b>Book thickness</b>	max. 80 mm (3 1/8" (C))
	min. 2 mm (1/16" (C))
<b>Trim</b> Front	max. 40 mm (1 9/16" (F))
	min. 3 mm (1/8" (F))
Head/Foot	max. 40 mm (1 9/16" (E/D))
	min. 2 mm (1/16" (E/D))

**Power requirements** 7 kW/50 Hz, 11 kW/60 Hz

**Air requirements** 40 m<sup>3</sup>/h at 6 bar (23 cfm at 87 psi)

**Weight** 3500 kg (7,700 lbs.)

## Size ranges of the cutting table cassettes

Formatausrüstung	Cassette number	Size range
Small sizes (option)	1	100 to 112 mm
	2	112 to 124 mm
	3	124 to 136 mm
Standard sizes	4	136 to 148 mm
	5	148 to 160 mm
	6	160 to 172 mm
	7	172 to 184 mm
	8	184 to 196 mm
	9	196 to 208 mm
	10	208 to 220 mm
	11	220 to 232 mm
	12	232 to 244 mm
	13	244 to 256 mm
	14	256 to 268 mm
	15	268 to 280 mm
	16	280 to 292 mm
	17	292 to 304 mm
Large sizes > A4 (optional)	18	304 to 316 mm
	19	316 to 328 mm
	20	328 to 340 mm
	21	340 to 352 mm
	22	352 to 364 mm
	23	364 to 376 mm
	24	376 to 388 mm
	25	388 to 400 mm
	26	400 to 412 mm
	27	412 to 424 mm
	28	424 to 434 mm

Other sizes on request.

Design, measurements and specifications subject to change.

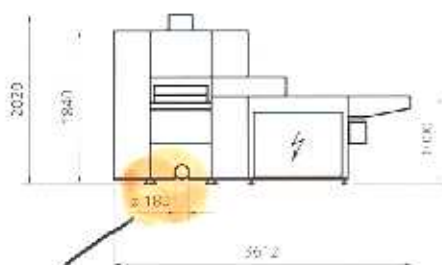

**Z MUST HAVE SUFFICIENT  
WASTE REMOVAL CAPACITY  
SAME AS BENTH-S**

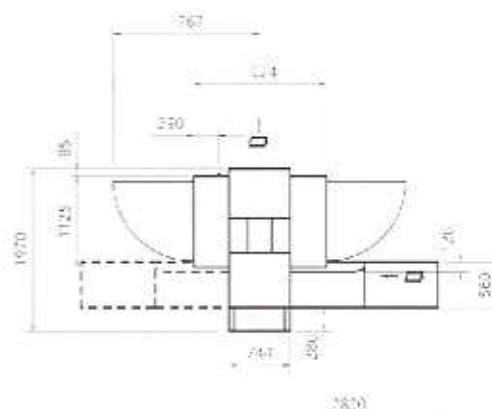

**MÜLLER MARTINI**

**Müller Martini Marketing AG**

Untere Brühlstrasse 13  
CH-4800 Zolingen, Switzerland

Phone — 41 62 751 45 75

Fax — 41 62 751 55 50



## **Merit S Three-knife Trimmer – the ideal combination of superior trim quality and production flexibility**

### **● Fast set-up**

The product mix processed by mid-size operations has become more diversified. Therefore, machines with very short makeready are needed to compete in today's market. The Müller Martini Merit S Three-knife Trimmer, with automatic make-ready system, ideally meets these requirements.

### **● Processing of a wide range of products**

The large size range and trim capacity allows the Merit S Three-knife Trimmer to efficiently handle a wide variety of perfect bound and thread sewn books.

### **● Processing of book blocks for case-binding**

The Merit S handles the most demanding needs with ease (trim thickness, cycle time, single or collect trimming).

### **● Operation and maintenance**

The Müller Martini sales and service network ensures support and a true partnership with users around the world.







Perfect trimming



Infeed

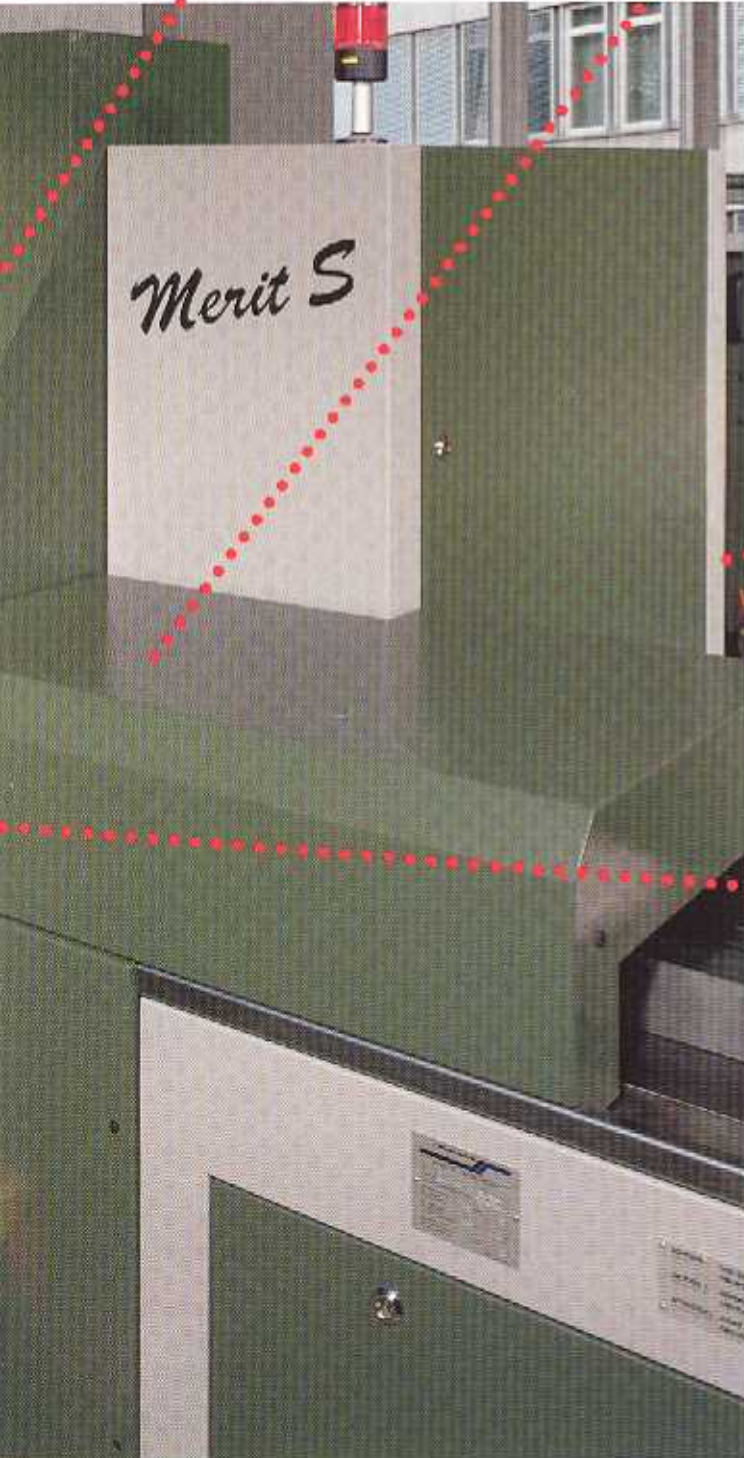

Delivery



Automatic makeready and control system

The Müller Martini Merit S Three-knife Trimmer is the key to versatility and profitable production in the bindery.



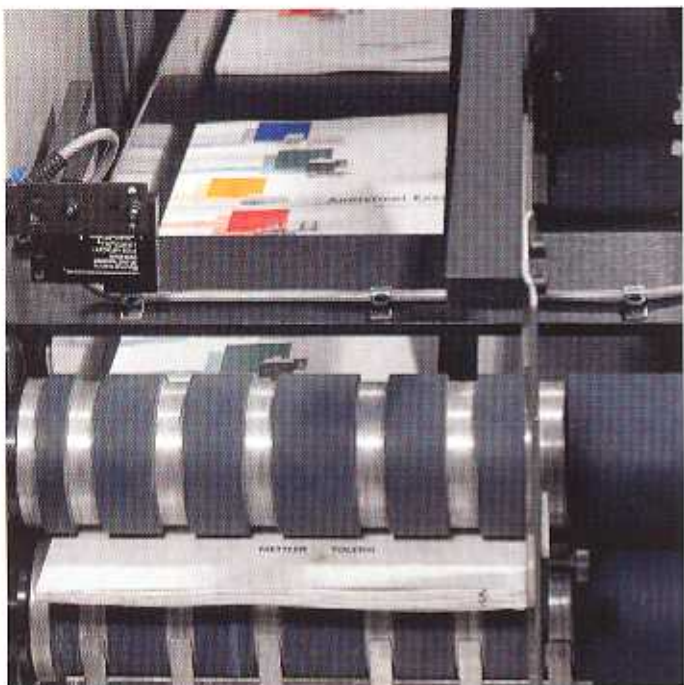

### **Infeed conveyor**

Greater infeed flexibility is a critical advantage for efficient production. Books enter the three-knife trimmer from the left or right, individually or in multiples. Thin products are handled gently and size settings of the hopper and knife station are automated.



### **Book infeed into the knife station**

Positively controlled infeed is a critical requirement for precise trimming. The products enter the knife station spine leading, thereby preventing curl-up of the endsheets or covers. Books gently decelerate as they approach the front stops (to avoid bounce) and are accurately aligned prior to clamping.

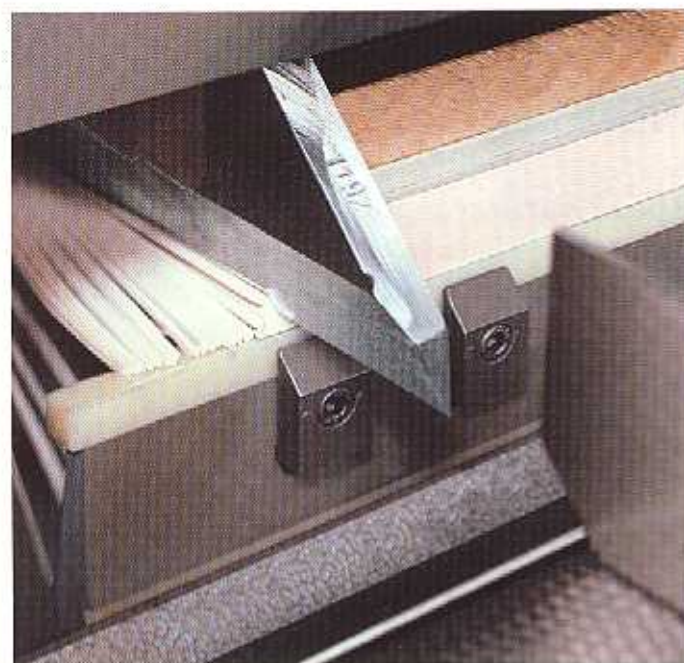

### **Knife station**

High trim quality is assured by the proper trim sequence. Face, head and foot are trimmed in one station. Books are pressed over their full area and clamp pressure is pneumatically adjustable. Trimming is done against plastic cutting sticks. Shear cutting action for head and foot trim is towards the spine to prevent tear-outs. For trim removal, the trimmer can be hooked up to an exhaust system or optional conveyor.



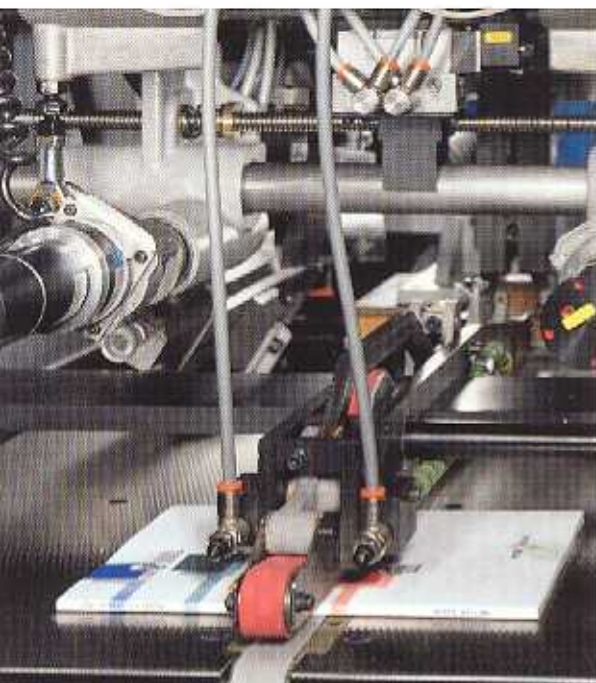

### **Book delivery**

Gentle handling of the trimmed books guarantees top trim quality and reliable downstream finishing. The delivery system ensures positive control without marking.

### **Automatic makeready and control system**

The interactive PLC provides convenient operation. It automatically sets up basic data for the book (size, speed, and clamp pressure). Subsequent orders can be pre-programmed and saved while production is running.

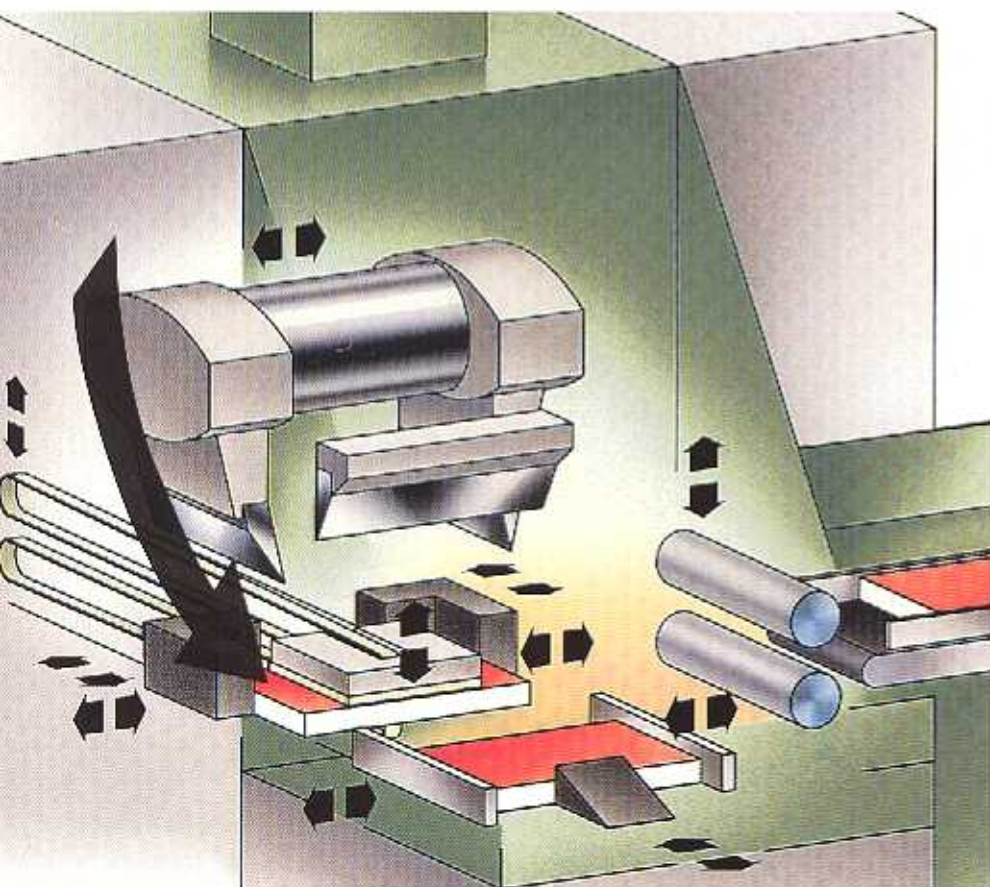

Motorized adjustments for size changes are made automatically after removal of the cutting table. Fine adjustments can be made on-the-fly. The Merit S uses the same control system as the Müller Martini Zenith S Three-knife Trimmer.

### **Shear cutting action**

Shear action trimming of the Merit S ensures superior quality and a clean cut. Trim quality is an important visual aspect of the printed product.



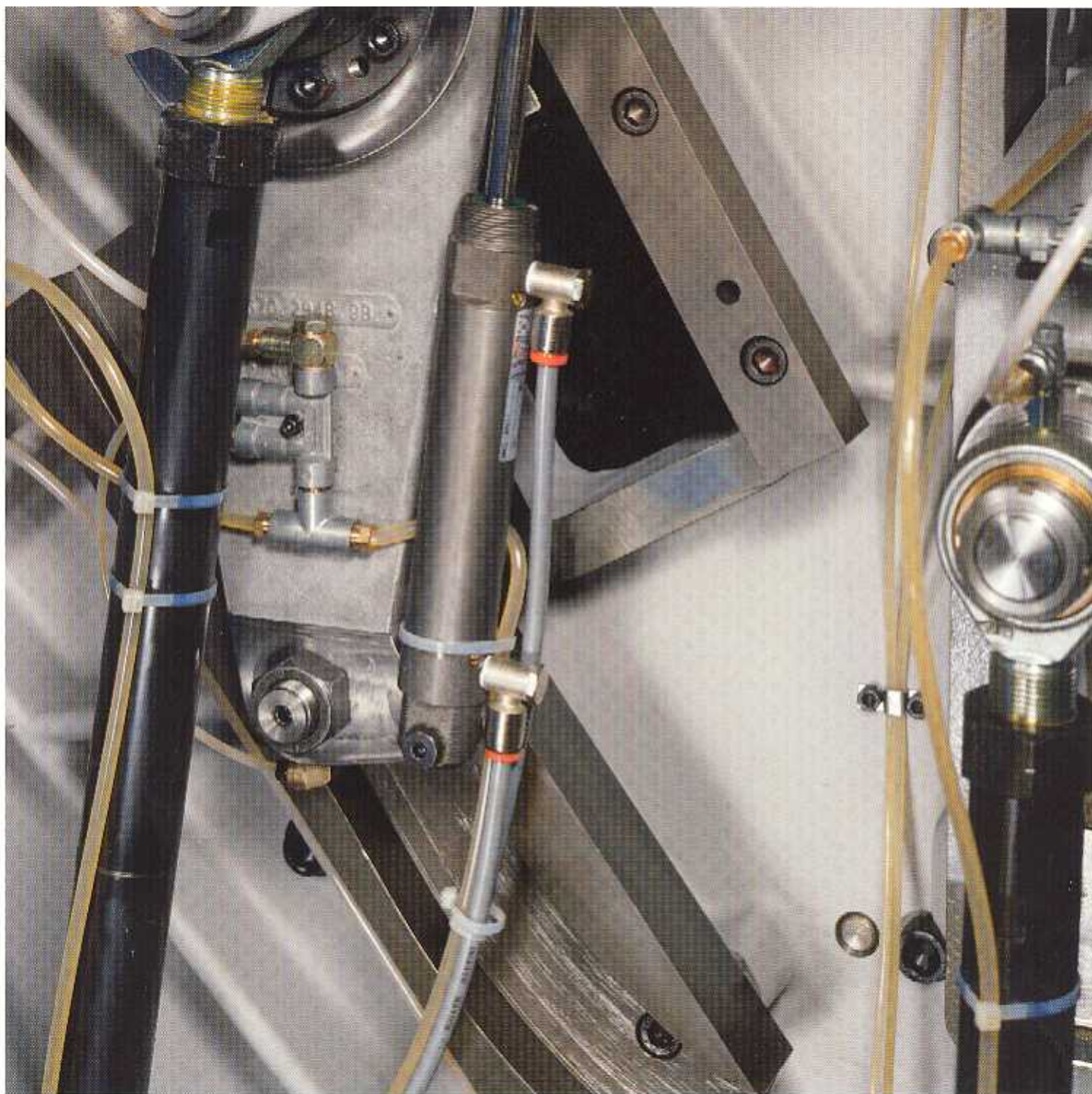

**Merit S,**  
the three-knife trimmer with  
exclusive shear cutting action

This brochure may show components which are not standard equipment and are available as options only.

In some cases protective covers have been removed or opened for illustrative purposes. They must be in place during machine operation.

Design, measurements and specifications are subject to change.

Sales and Service

**MÜLLER MARTINI**

**Müller Martini Marketing AG**

Untere Brühlstrasse 13  
CH-4800 Zofingen, Switzerland

Phone ++41-62/745 45 75

Fax ++41-62/751 55 50