



IBIS Smart-binder Operator's Manual

For SB1, SB2, SB3 and SBX



Preface

IBIS Integrated Bindery Systems Ltd, is specifically not liable for any damage or injury arising from failure to follow the instructions contained in this manual, or failure to exercise due care in the installation, operation, and servicing of this equipment.

This manual applies to Smartbinders running **Version 7** software.

Spare Parts and Service:

For spare parts and service enquiries, please contact:

IBIS Integrated Bindery Systems Ltd
Cressex Business Park
High Wycombe
Buckinghamshire
UK
HP12 3SU

+44(0)1494 561950

Email: service@ibis-bindery.com

Revision History

Revision	Date	Description of Change	ECR No
00		First Issued	

Contents

1	Safety.....	4
2	Using the Smart-binder	6
2.1	Operating the Smart-binder.....	6
2.1.1	Turning on.....	6
2.1.2	Turning off.....	6
2.2	Control Panel Functions.....	8
2.2.1	Operator's pushbuttons.....	8
2.2.2	The Main Menu	9
2.3	Adjust the Smart-binder for a new job	10
2.3.1	Load an existing setup	10
2.3.2	Adjust the Infeed and Collator for a different sheet size	10
2.3.3	Adjust the Cover Feeder for different cover size and material	14
2.3.4	Adjust the Push out conveyor so that the book is centred in the trimmer.....	17
2.3.5	Adjust the distance between stitches	18
2.3.6	Adjust the Stitches for book thickness.....	19
2.3.7	Adjust the Backstops for the size of the book.....	20
2.3.8	Adjust the Side Knives for the size of book	21
2.3.9	Adjust the Trimmer Side Joggers	22
2.4	Enter new setup parameters	23
2.4.1	Loading, saving and deleting setups.	23
2.4.2	Setup – Sheets	24
2.4.3	Setup – Barcodes	25
2.4.4	Setup - Books	27
2.4.5	Setup - Gluing.....	28
2.4.6	Setup - Perforator	29
3	Other functions.....	30
3.1	Display information about the operation of the Smart-binder	30
3.2	Changing machine operating modes.....	31
3.2.1	Makeready options.....	32
4	Fault Finding	33
4.1	Book Quality.....	33
4.2	Making fine adjustments.....	38
4.2.1	Adjust the position and angle of the infeed registration guide.....	38
4.2.2	Place the Infeed Conveyor Balls	38
4.2.3	Adjust the sheet and cover Scoring pressure	39
4.2.4	Adjusting the hold down fingers.....	39
4.3	Fault Messages.....	40
4.4	Warning Messages (grey)	44
4.5	Warning messages that require operator intervention (blue)	44
6	Maintenance	45
6.1	Maintenance Intervals.....	45
6.1.1	Every 16 hours of running	45
6.1.2	Every 200 hours of running	45
6.2	Maintenance operations.....	45
6.2.1	Cleaning belts and rollers.....	45
6.2.2	Cleaning clincher area	45
6.2.3	Cleaning excess grease from trimmer bearings	45
7	Appendix A.....	46

1 Safety

- ◇ **Press-in the Emergency Stop Button during maintenance or while making adjustments.**
- ◇ **Check that all the Guards are in place.**

The Guards shown opposite are installed to protect you from moving parts that are potentially hazardous. Never remove or change any of the guards.
- ◇ **Never override any of the machine interlocks**
- ◇ **Observe all Warnings and Cautions, they are there for your safety.**

WARNING

A Warning is placed before any procedure that if not followed could result in personal injury.

CAUTION

A Caution is placed before any procedure that if not followed could result in damage to the equipment.

- ◇ **Ensure that the floor around the machine is kept clear of all obstacles.**
- ◇ **Wear clothes in a manner that eliminates the possibility of being snagged by the machine.**
- ◇ **This equipment must be installed, adjusted and serviced by qualified personnel, who have been trained in its commissioning, service and operation.**

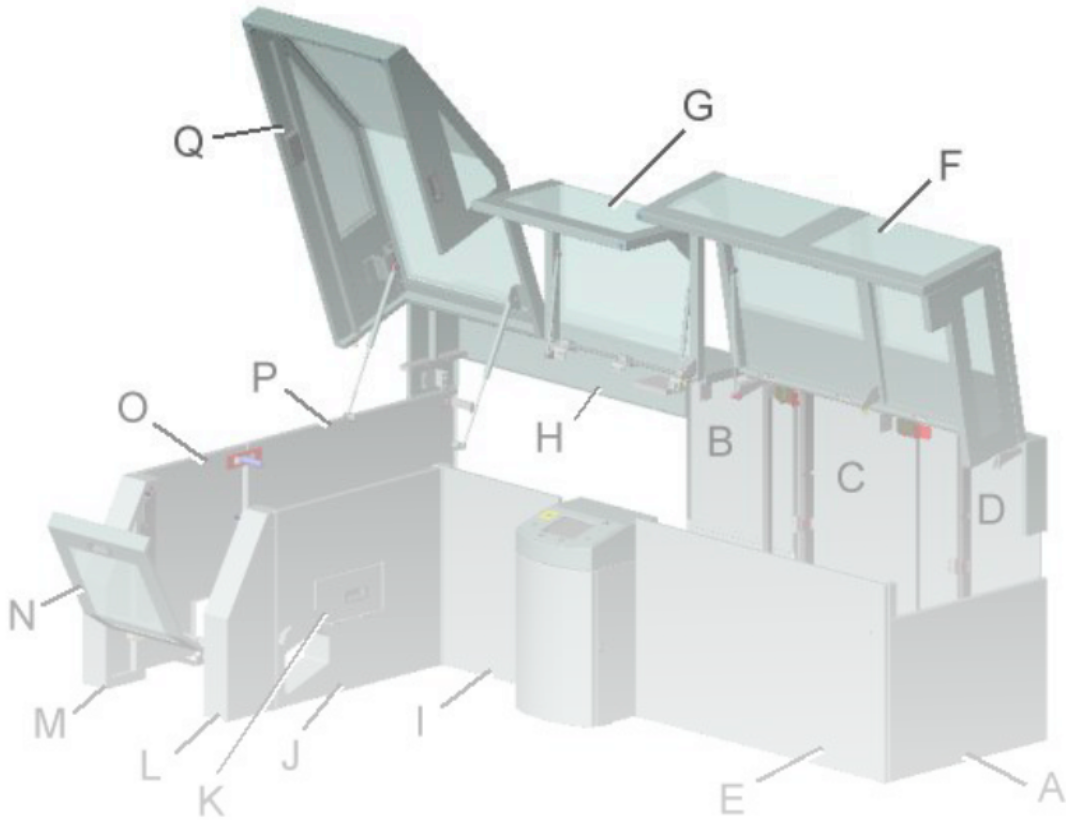

- | | | | |
|---|---------------------------------|---|---------------------|
| A | Scoring area, end fixed guard | J | Trimmer fixed guard |
| B | Scoring area, rear fixed guard | K | Trimmer side guard |
| C | Scoring area, rear fixed guard | L | Trimmer fixed guard |
| D | Scoring area, rear fixed guard | M | Trimmer fixed guard |
| E | Scoring area, front fixed guard | N | Reject guard |
| F | Scoring area, guard | O | Trimmer fixed guard |
| G | Stitcher guard | P | Trimmer fixed guard |
| H | Stitcher rear fixed guard | Q | Trimmer guard |
| I | Stitcher front fixed guard | | |

Now The **FOR FULL MANUAL ACCESS CONTACT**
PARTS DEPARTMENT

Mike Keller

800-236-7603 ext. 1010
 SUBMIT REQUEST ONLINE



BEST GRAPHICS
FULL SPECTRUM PRINT | PACKAGING | DIGITAL

CALL FOR DETAILS | 800-236-7603 | bestgraphics.net