



## 自动预给纸机

FOLDER GLUER PRE-FEEDER

## 半自动收纸机

SEMI-ATUO COLLECTING TABLE

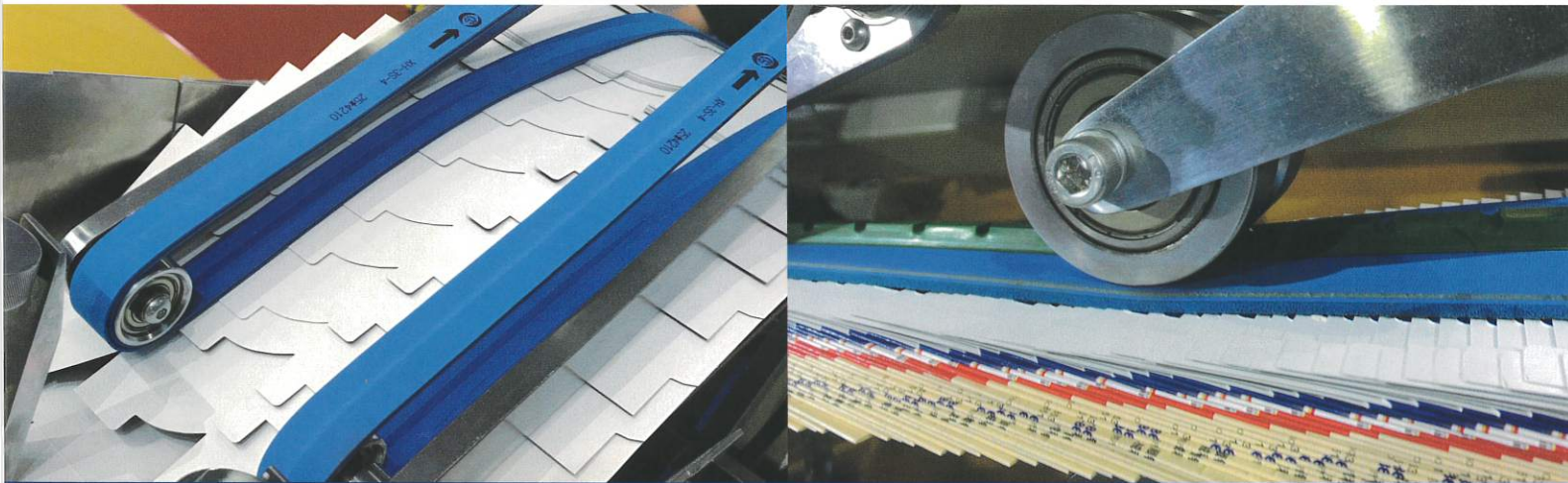

東莞市順欽機械有限公司  
DONGGUAN SHUNCHIN MACHINERY CO.,LTD.

東莞市索科機械科技有限公司  
DONGGUAN SOCO MACHINERY CO.,LTD.

地址：中國廣東省東莞市橫瀝鎮月塘工業區

Add: Yuetang Industrial Estate, Hengli Town, Dongguan City, Guangdong Province, China.

TEL: +86-769-86573630 86341680 FAX: +86-769-86573320

Mobile: +86-13038810510 QQ: 銷售 2885380385 客服 2885181518

E-mail: alan@scmsoco.com Http://www.scmsoco.com



# 半自动收纸机

SEMI-ATUO COLLECTING TABLE

## SO-1-350

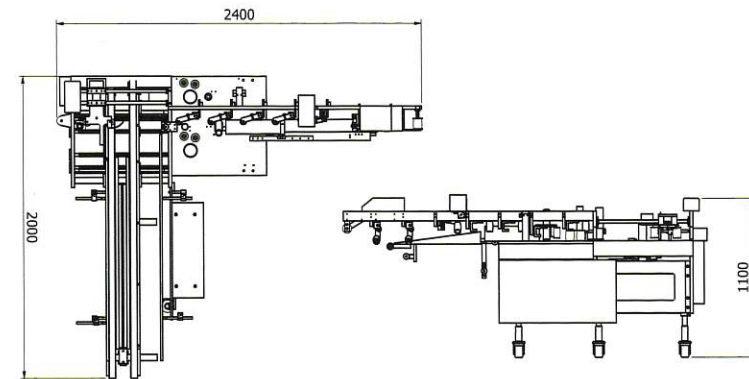

### 技术参数 / SPECIFICATION

型号 Model	SO-1-350	
适用纸质 For Use Materials	纸板 Cardboard	200-600克
适用盒型 For Use Materials	边贴盒 Straightline cartons	
最大盒子尺寸 Max Output Paper Size	350*380mm	
最小盒子尺寸 Mini Feed Size	50*80mm	
给纸最大厚度 Max Layer Thickness	50mm	
总功率 Total Power	1.5KW	
整机重量 Total Weight	0.62T	
外形尺寸 Dimensions Size	2400*2000*1100mm	

# SEMI-ATUO COLLECTING TABLE



## SO-2-500

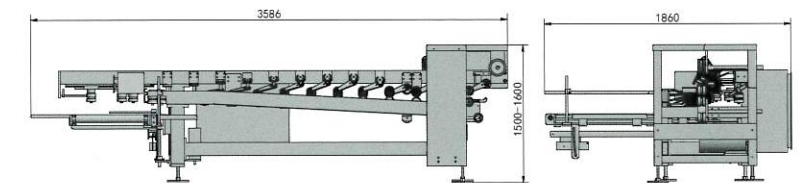

### 技术参数 / SPECIFICATION

型号 Model	SO-2-50	
适用纸质 For Use Materials	纸板 Cardboard	200-800克(N F E)
适用盒型 For Use Materials	边贴盒、两侧边贴盒、勾底盒、四角盒、六角盒 Straightline cartons/ Lockbottom cartons/ Double wall boxes/ 4-corner collapsible boxes/ 6-corner collapsible boxes	
最大盒子尺寸 Max Output Paper Size	400*500mm	
最小盒子尺寸 Mini Feed Size	50*80mm	
给纸最大厚度 Max Layer Thickness	80mm	
总功率 Total Power	2.8KW	
整机重量 Total Weight	0.85T	
外形尺寸 Dimensions Size	3860*2100*1100mm	

无与伦比的辅助设备，运用SO收集糊盒机制成产品，可使后续包装作业更容易。SO乎可以处理所有类型的箱子，进而增加糊盒机的生产效率，减少人力，让投资得到确实的回报！

- 适用于中小型糊盒机生产盒样的收集
- 可调整速度与输送机同步
- 轻松收集产品
- 设定操作容易
- 机台可轻松移动
- 可配合输送机调整机身高度

An unrivalled multipurpose tool, the SO enables the collection of folding boxes, and makes hand packing easy. compact and user friendly, it handles almost all types of boxes. The SO increase the productivity of your folder-glue, thanks to the ease of collection it offers with a minimum of staff at the delivery, ensuring a proven return on investment!

- Optimized run for small sizes and easy adaptation to most universal Folder Glue.
- Accurate synchronization of the collection conveyor speed with the arrival of the box layer.
- Easier collection of boxes and machine operation.
- Easy and quick set-up.
- Caster mounted it can be moved around with ease.
- Adjustable height of the collection conveyor.