

SCM

SCM/SOCO

自动预给纸机

FOLDER GLUER PRE-FEEDER

半自动收纸机

SEMI-ATUO COLLECTING TABLE

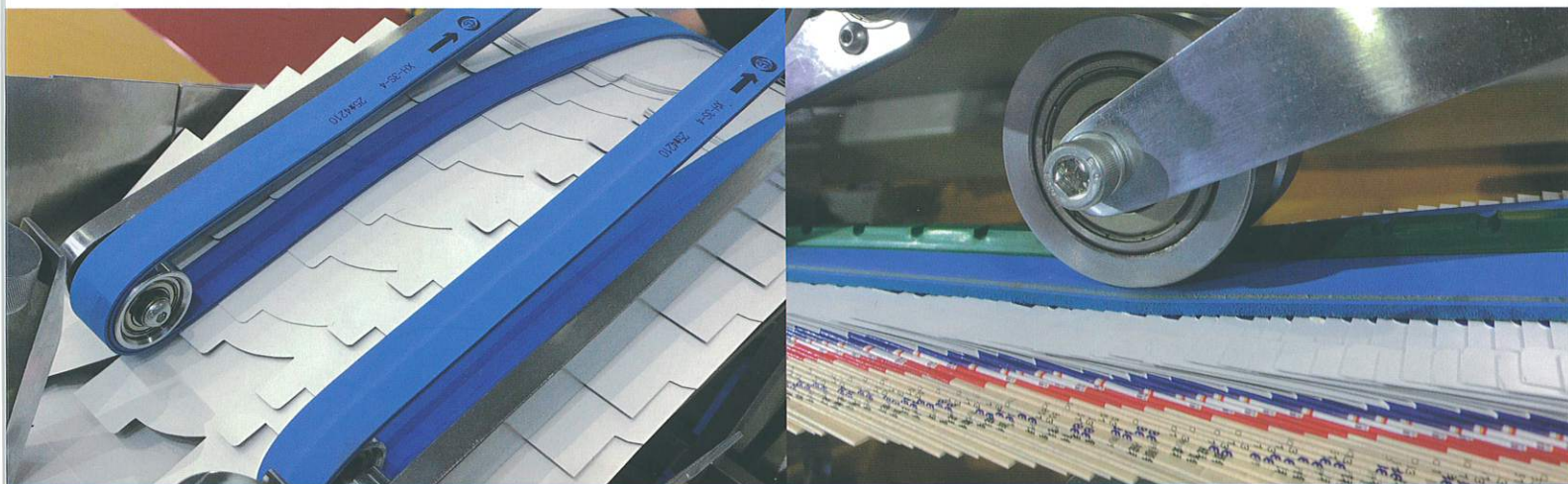

東莞市順欽機械有限公司
DONGGUAN SHUNCHIN MACHINERY CO.,LTD.

東莞市索科機械科技有限公司
DONGGUAN SOCO MACHINERY CO.,LTD.

地址：中國廣東省東莞市橫瀝鎮月塘工業區

Add: Yuetang Industrial Estate, Hengli Town, Dongguan City, Guangdong Province, China.

TEL: +86-769-86573630 86341680 FAX: +86-769-86573320

Mobile: +86-13038810510 QQ: 銷售 2885380385 客服 2885181518

E-mail: alan@scmsoco.com Http://www.scmsoco.com



自动预给纸机

FOLDER GLUER PRE-FEEDER

配合高速生产，可选配预叠纸台预先放置较多的产品提升生产效率，减少作业时间。

With high-speed production, optional per-stacker units to improve production efficiency.

Prepositioned more products, reduce working time.

- 符合人体工学的工作条件
 - 大大降低准备时间
 - 与糊盒机给纸部速度一致
 - 提供更高的生产率和优异的产品质量
 - 提升净产值，单位成本降到最低
- Ergonomic working conditions.
 - Greatly reduced makeready times.
 - High reliability in production thanks to consistent conditions in the gluer feeder.
 - Higher productivity and outstanding product quality.
 - Higher net output while maintaining the same number of staff; unit costs are minimized long term.

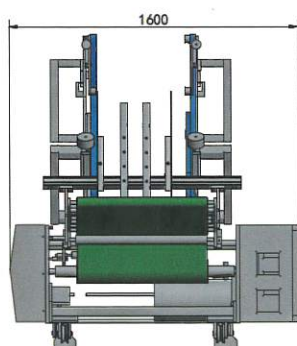
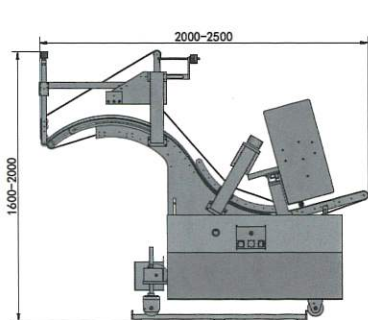

技术参数 / SPECIFICATION

型号 Model		PF-650	PF-750	PF-1100	PF-1450
适用纸质 For Use Materials		纸板 Cardboard 200-600克		纸板 Cardboard 250-800克(N F E)	
最大输纸尺寸 (单张) Max Output Paper Size (Single)		650*460mm	750*480mm	1100*600mm	1450*700mm
最小输纸尺寸 (单张) Mini Feed Size (Single)		100*90mm	100*90mm	100*90mm	150*100mm
给纸最大厚度 Max Layer Thickness		500mm	500mm	500mm	500mm
总功率 Total Power		2.2KW	2.2KW	3.2KW	4.6KW
整机重量 Total Weight		1.0T	1.1T	1.3T	1.8T
外形尺寸 Dimensions Size		2150*1380*1560mm	2150*1480*1560mm	2150*1830*1560mm	2350*2180*1580mm