



TEC Lighting, Inc.

905 Mariner St., Brea, CA 92821 • phone: 714.529.5068 • fax: 714.529.0344
www.teclighting.com

TEC Lighting is a world leader in the design, manufacture, and distribution of UV lamps, curing equipment, and special energy sources. We have over 100 years of combined experience in UV curing technology. Our flexible approach to engineering, problem solving and development of processes make us an ideal partner for your curing applications.

Our goal is to help you focus on your primary business while we provide you with the knowledge and the access to technology that will support your project requirements. No one can match our ability to design for efficiency and better performance.

In addition to our manufactured products, TEC Lighting is partnered with key suppliers to provide lamps for medical devices, cinema projectors, exposure machines, and other unique lighting fixtures.

Offline UV Coater Specifications

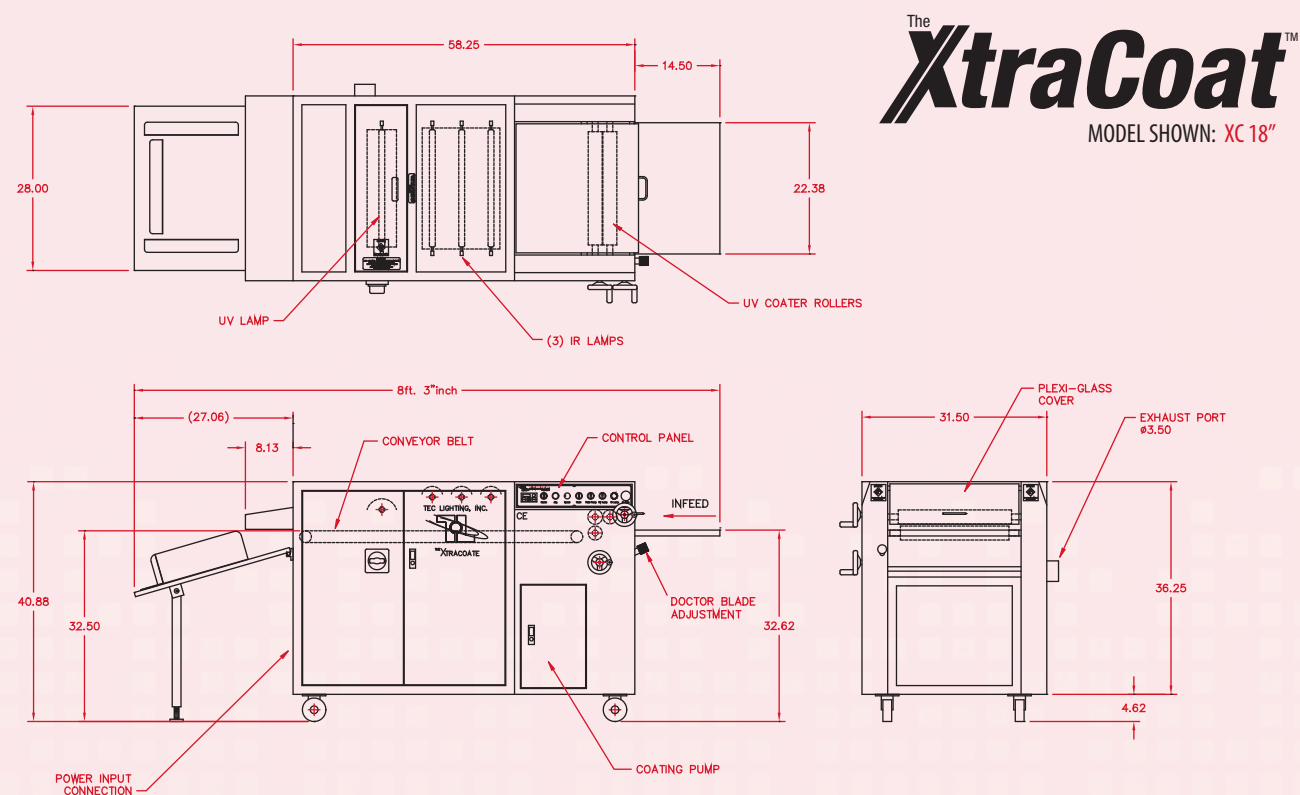

MODEL NUMBER	MAX SHEET	DESCRIPTION	SIZE	VOLTAGE INPUT
XC18-1-3D	18" wide	Hand-fed offline UV coater / UV & IR lamp conveyor	8'3" w x 40.88" h x 31.5" d	208/220 - 240 VAC 1 Phase, 60HZ, 40 AMPS
XCF18-1-3D	18" wide	Offline UV coater with feeder / UV & IR lamp conveyor	9'11" w x 44" h x 31.5" d	208/220 - 240 VAC 1 Phase, 60HZ, 55 AMPS
XC25-1-3A	25" wide	Hand-fed offline UV coater / UV & IR lamp conveyor	8'9" w x 44.75" h x 39.25" d	208/220 - 240 VAC 3 Phase, 60HZ, 65 AMPS
XCF25-1-3A	25" wide	Offline UV coater with feeder / UV & IR lamp conveyor	10'5" w x 44.75" h x 39.25" d	208/220 - 240 VAC 3 Phase, 60HZ, 75 AMPS
XCF29-1-3A	29" wide	Offline UV coater with feeder / UV & IR lamp conveyor	12' w x 44.75" h x 43.25" d	208/220 - 240 VAC 3 Phase, 60HZ, 90 AMPS



World leader in the design and manufacturing of UV Coating and Curing Solutions

Imagine the possibilities of ON DEMAND UV Coating for...

Book covers • Variable data printing • Direct mail • Business cards • Brochure • Post cards & More!

www.teclighting.com

The XtraCoat™ Offline UV Coater

The Tec Lighting XtraCoat Offline UV Coating system offers the ideal combination of performance and affordability. The XtraCoat lineup was designed with your needs and desires as a main priority. The XtraCoat Offline UV Coater will give you the ability to Gloss and Satin coat almost any printed sheet with ease. The system is offered in many configurations to fit your requirements, sizes range from 18" to 30" with a modular design to allow for added components such as an automatic feeder for increased production in the future. Let us show you the increase in capabilities and profit that you can achieve with the addition of the Tec Lighting XtraCoat Offline UV Coating system.

XtraCoat Offline UV Coater Features

Automatic feeder:

Deep pile automatic Feeder offers 18" stack capacity, 1" spaced sucker feet and a Double sheet detector with deflector plate to ensure smooth and consistent feeding.

Roller chamber:

Three roll coating application system with stainless steel doctor blade. Each roller is independently controlled with a worm gear to ensure even pressure across the roller.

Doctor blade system:

Precision Stainless steel doctor blade system keeps bottom impression roller clean from any coating transferred by the applicator roller.

IR/UV lamp head:

The system incorporates both IR and UV lamps in the curing process. The 3 lamp IR section will help flow out UV coating. The design of the UV lamp reflector guarantees maximum light output at lower operating voltages.

Advantages of UV Coating

Compact easy to use design:

The compact design of the XtraCoat UV Coaters offers a remarkably smaller footprint than a comparable UV Coater with all the features of the XtraCoat UV Coater. The unit fits seamlessly into print shops of any size. The simple design also eliminates the need for highly trained personnel to operate the system. All operator training is done by Tec Lighting technicians at your pace, at your location.

Quality you can see:

Within 5 minutes of turning on power to the system you will begin to UV coat your prints with quality UV Coating. The results are immediate; you will notice a remarkably enhanced sheet with a stunning finish and image protection ready for anything you can throw at it.

Environmentally friendly:

UV Coating with the XtraCoat UV Coater may just be the most environmentally friendly way to apply a finish to your printing. The TEC COAT™ line of UV coatings are 99.9% VOC free and meet or exceed all environmental air quality regulations.

The Three P's

With the addition of UV Coating you can enjoy the benefits of maximizing the abilities of your existing presses and digital engines. Adding a topcoat to a printed piece will give you the **3 P Advantage.**

Protection

Direct mail, book covers, heavily handled prints, water and chemical resistance

Product Enhancement

Visual appeal, different finishes, high-end look and feel, intensifies dark colors and brings out small detail

Profitability

Sell your printing for higher profits, create new business and move work faster through production with the ability to seal the ink or toner and get the job out the door.



Go Green!
No VOC

#1 Coating & Print Enhancement Solution!

