

Cutter 561 / 562

High performance cut



- ✓ *Rotary knife for maximum precision*
- ✓ *Guaranteed 22 million cuts*
- ✓ *1-, 2- or 3-up offset*
- ✓ *In-line operation*

Service Area

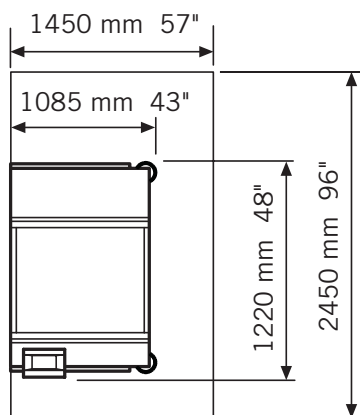

Technical Specifications

Performance / Media

Speed max.	450 ft/min	137 m/min
Feeding	Pinfed or pinless	
Paper weight	10.7# bond - 53# bond index 40 - 200 gsm (S/M 2 x 100 gsm)	
Web width	5.5" - 20.5"	140 mm - 520 mm
Sheet length	3.5" - 100"	90 mm - 2500 mm
Output option	1-, 2-, 3-up with offset	
Offset	0,6"	15 mm

Options

Center slitter, Antistatic equipment, Connections for granulator, Trim chopper, Loop box

Electrical

Power	10A, 200-240 VAC, 50/60 Hz or (North America) 15A, 1 Phase, 208 V, REC=L6-15R	
Consumption	650 W (in use)	300 W (idle)
Heat output	1770 BTU/h	

Environmental

Temperature	60 - 80° F	15 - 27° C
Acoustics	72 dB(A)	
Humidity	40 - 60%	

Dimensions

Length	43"	1085 mm
Width	48"	1220 mm
Height excl. display	46"	1165 mm
Weight	561 840 lb	380 kg
	562 990 lb	450 kg
Color	Gray	

Approvals

CE (98/37/EG), EMC Class A, LVD, CB EN 60950, cULus 1950 3rd, FCC15 Class A, VCCI

Product Specifications



15092014

©2014 Tecna. All rights reserved. The Tecna name and logo are trademarks of Tecna. Tecna reserves the right to make any technical amendments without prior notification.



TECNAU
w w w . t e c n a u . c o m

Europe	Italy	+39 0125 631678	info.it@tecna.com
	Sweden	+46 372 256 00	info.se@tecna.com
Americas	USA	+1 978 608 0500	info.us@tecna.com
Asia Pacific	China	+86 159 00710147	info.cn@tecna.com
	Singapore	+65 6793 9478	info.sg@tecna.com