

CHALLENGE

CMT 130TC

ON-DEMAND BOOK TRIMMER

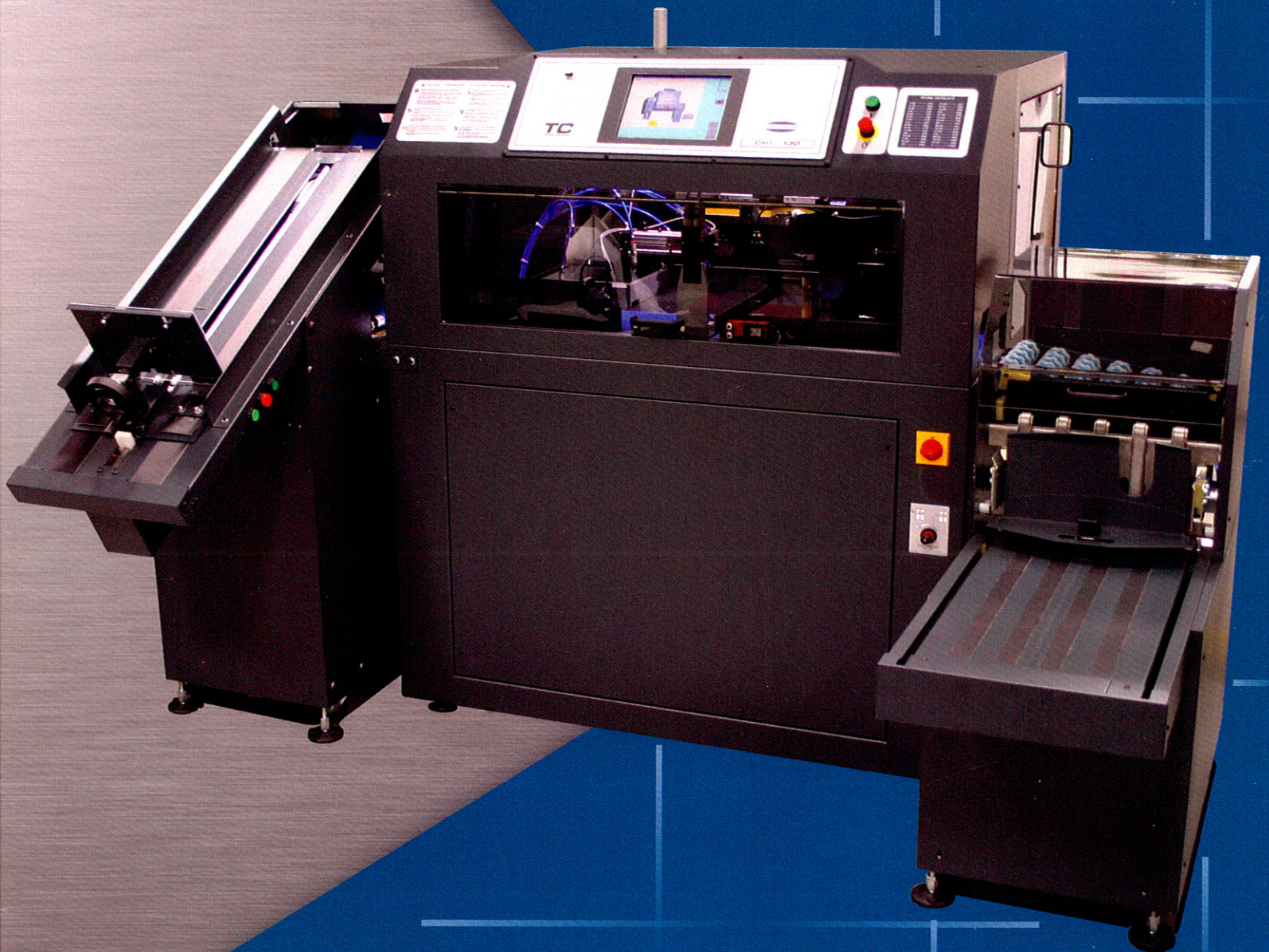

ASSURANCE YOU MADE THE RIGHT DECISION

CMT 130TC ON-DEMAND BOOK TRIMMER

The CMT 130TC is the only truly modular perfect-bound book trimmer capable of fulfilling

CMT 130TC

Perfect-bound book manufacturing just got better! The process of perfect-bound book trimming has long been a labor-and-cost-intensive task. The Challenge CMT 130TC trimming system, the industry's only truly modular trimmer capable of fulfilling a combination of both near-line and in-line feeding, has gone to the next level in automation and productivity.

HIGH QUALITY FINISHING

The Challenge CMT 130TC On-Demand Book Trimmer is designed and built in the USA using durable steel and cast-iron construction. Powerful hydraulic cutting and adjustable clamping pressure will effortlessly cut up to a 2" (5cm) thick book. A distinct clamp design and a bi-directional knife stroke assures that the knife always cuts into the spine providing excellent trim quality. The NEW Precision Knife Depth Control provides consistent and complete control of knife stroke depth during the trim cycle reducing wear to cut sticks and the need for continued knife adjustments.

EFFICIENT & FULLY AUTOMATED

The CMT 130TC utilizes servo and stepper motors to accurately position and rotate the book block for trimming. Full digital control of the set-up allows the trimmer to perform book size changes in less than 10 seconds and never requires tools to perform manual adjustments or exchange book clamps like other trimmers in the marketplace. The CMT 130TC exclusively features integrated in-line and near-line feeding capability allowing the trimmer to automatically switch between feeding books from the

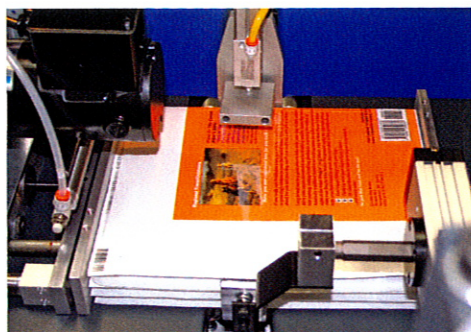

MULTIPLE BOOK MODE INCREASES PRODUCTION CAPACITY

The CMT 130TC features a multiple book mode which allows for up to three books to be trimmed simultaneously (to a maximum pile height of 1-1/4") further increasing production capacity.

in-line system directly from the perfect binder OR the near-line book pile feeder system that is manually loaded. If one system is waiting for its next book, the other system can feed the trimmer providing maximum

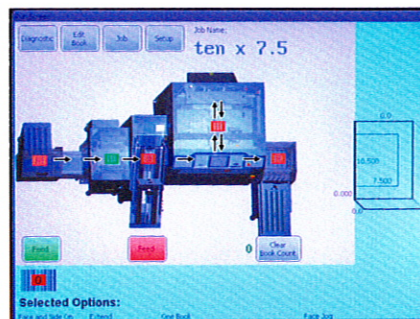

LIVE GRAPHICAL DISPLAY OF BOOK POSITION DURING OPERATION

book path during operation and smart diagnostic assistance makes the CMT 130TC the leader of the industry for operational simplicity. Automatic size detection of the pre-trimmed book reduces the required job program entries to only three dimensions. This advanced simplicity allows complete programs to be translated into a simple barcode. By printing the book's trim dimensions in a barcode on its cover located in the bleed (or trim) area, the CMT 130TC can use its integrated bar code reader to read the barcode and set-up for the book automatically! Simply stated, the CMT 130TC is a true FULLY AUTOMATED book-of-one trimming solution. It is able to perform automatic set-ups for each and every book as it arrives for trimming.

ADAPTABLE

The CMT 130TC is the only trimmer in its class that is a truly adaptable, modular trimming system. The base CMT 130TC can be hand fed for a low cost off-line solution. The addition of the near-line high capacity Book Pile Feeder and the Vertical Stacker provides long intervals of unmanned and uninterrupted operation (system shown on front cover). When configured or coupled with our In-Line Feeder and Cooling Elevator devices, the CMT 130TC becomes integrated with your perfect binder to become a complete book making system. The CMT 130TC is uniquely adaptable to grow as your business grows!



CMT 130TC CONTROL PANEL

WORLD CLASS TECHNOLOGY

The CMT 130TC 3-side trimmer incorporates the most advanced technology available. The new 10.5" color touch screen display provides a large intuitive operator interface. Live graphical display of the

IN-L

g your off-line, near-line, or in-line finishing requirements.

SUMMARY OF FEATURES

- 10.5" color touch screen display
- Live graphical display of book path
- Integration of both in-line & near-line feeders allowing alternate feeding systems
- Integrated bar code reader reads barcoded jobs allowing fully automated set-up
- Automatic size detection of untrimmed book blocks
- Precision knife depth control reduces cut stick wear and knife depth machine adjustments
- Trimmed book sizes 4" x 5.82" / 102mm x 148mm to 9" x 12" / 229mm x 305mm
- Trims books up to 2" / 51mm thick
- Full digital control for fast and accurate set-up in under 10 seconds
- Hydraulic powered cutting
- Adjustable clamp pressure
- No tools or clamp boards required during book size changes
- Integrated computer diagnostics with graphical display of sensor locations
- Minimal maintenance requirements
- UL listed (US and Canada) and CE

MADE IN

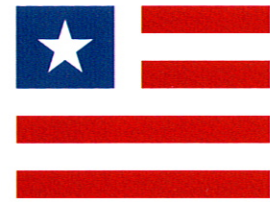

THE USA

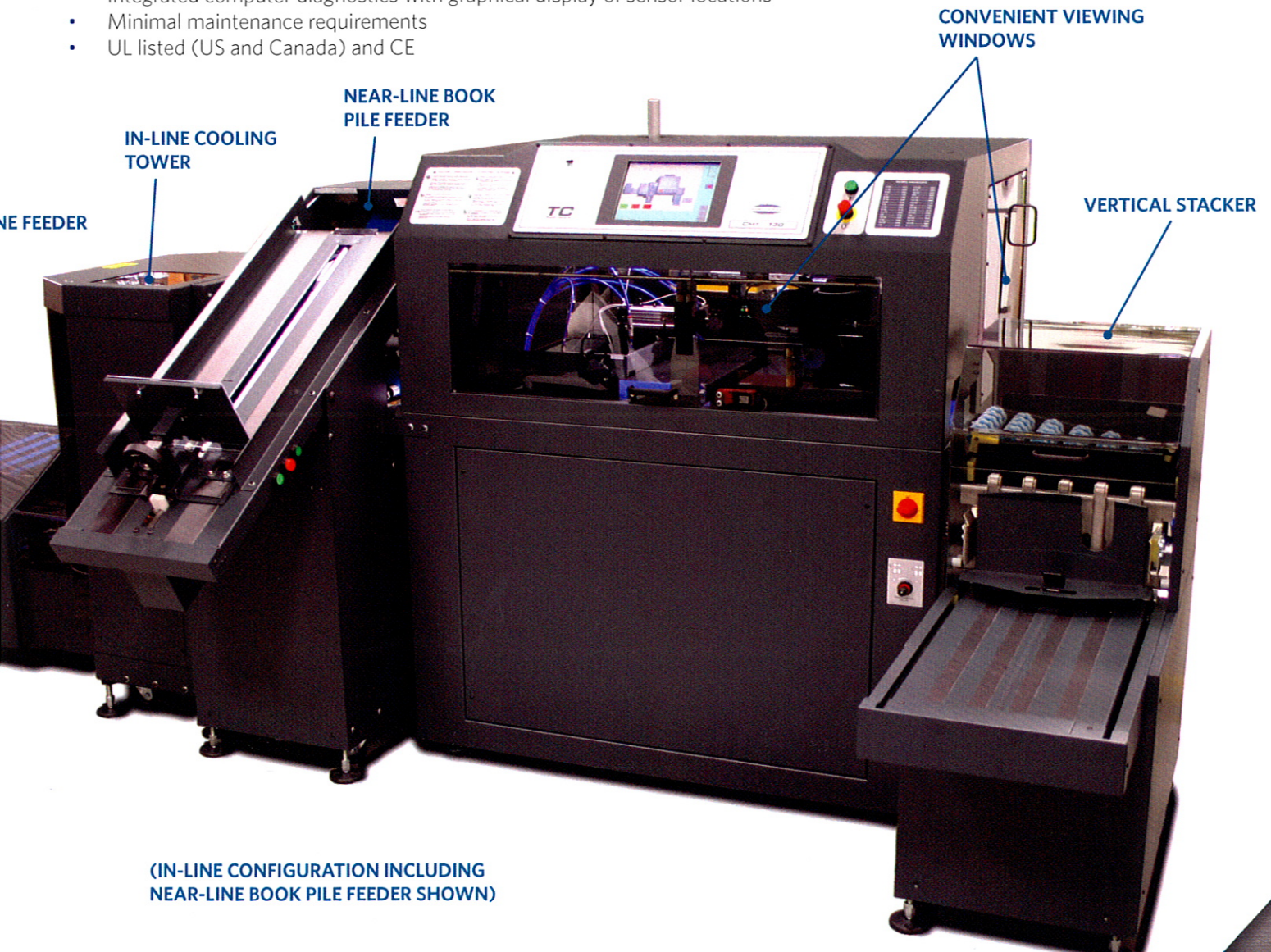

(IN-LINE CONFIGURATION INCLUDING NEAR-LINE BOOK PILE FEEDER SHOWN)

CMT 130TC ON-DEMAND BOOK TRIMMER

SPECIFICATIONS - BASE MACHINE

- Memory - 99 jobs or unlimited with USB
- Time to change book size - Approx. 10 seconds
- Throughput - *Up to 200 books per hour in single book mode
- Floor loading - 53 PSI / 3.73 kg/cm²
- Waste bin capacity - 43 gallons / 164 liters
- Oil capacity - 5 gallons / 19 liters
- Knife re-grind - 1/4" / 6.4 mm
- Air consumption - 5 CFM @ 90 PSI / 142 LPM @ 6 BAR
- *Multiple book mode - throughput up to 500 books per hour

PERFECT BOUND BOOK SIZE

- Starting size (maximum) 13" (spine) X 9-1/2" / 330 mm X 241 mm
- Starting size (minimum) *See configurations below
- Finish size (maximum) 12" (spine) X 9" / 305 mm X 229 mm
- Finish size (minimum) 5.82" (spine) X 4" / 148 mm X 102 mm
- Trim amount (minimum) 0.100" / 2.5 mm
- Face trim (maximum) 5-1/2" / 140 mm

ELECTRICAL

- Standard Motor: 5 HP, three-phase, 60 Hz, AC 208 / 230 VAC, 20 Amps (service size: 30 Amps)
- Optional Motor: 5 HP, three-phase, 50 Hz, AC 380 / 415 VAC, 10 KW, 12 Amps (service size: 15 Amps)

AIR SUPPLY

- The machine requires a "dry - non lubricated" air source capable of supplying a MINIMUM of 5 CFM (142 LPM) and MUST MAINTAIN a MINIMUM 90 PSI (6 BAR / 620 KPA)

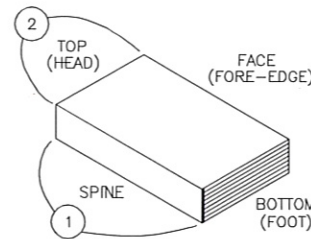

1 x 2 in. (mm)

SPECIFICATIONS - COMPONENTS

COMPONENT	HEIGHT	WIDTH	DEPTH	NET WT. (approx.)	SHIPPING WT. (approx.)
Base Machine	60" / 152.4 cm	52" / 132.1 cm	57" / 144.8 cm	1500 lbs / 680 kg	1800 lbs / 816 kg
Cooling Elevator	45-1/2" / 116 cm	21-1/2" / 55 cm	37" / 95 cm	335 lbs / 152 kg	470 lbs / 214 kg
In-Feed Conveyor	26" / 66 cm	40" / 102 cm	29" / 74 cm	150 lbs / 68 kg	230 lbs / 105 kg
Long Hand-Feed Conveyor	44" / 112 cm	35" / 89 cm	12-1/8" / 31 cm	95 lbs / 43 kg	220 lbs / 100 kg
Standard Hand-Feed Conveyor	11" / 27.9 cm	14-3/4" / 37.46 cm	15-3/4" / 40 cm	40 lbs / 18.2 kg	80 lbs / 36.4 kg
Book Pile Feeder	53-23/32" / 136.4 cm	20-9/32" / 51.5 cm	56-1/8" / 142.6 cm	370 lbs / 168 kg	420 lbs / 191 kg
Exit Conveyor	39-1/2" / 101 cm	47" / 120 cm	12-1/8" / 31 cm	85 lbs / 39 kg	210 lbs / 95 kg
Vertical Stacker	47-3/8" / 120.3 cm	19-5/16" / 49.1 cm	43-3/16" / 109.7 cm	218 lbs / 99 kg	268 lbs / 122 kg

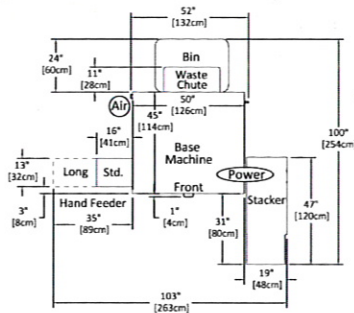

SAMPLE HAND-FEED CONFIGURATION

Book Start Size (minimum)
7" x 5" / 178 mm x 127 mm

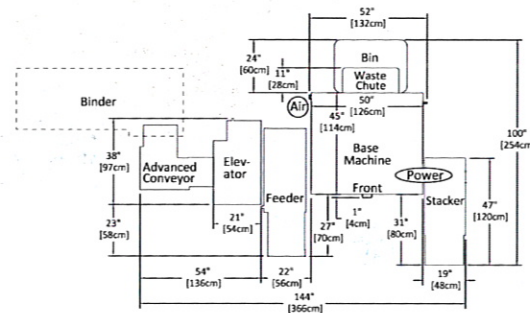

SAMPLE IN-LINE CONFIGURATION

Book Start Size (minimum)
7" x 6-3/4" / 178 mm x 171 mm

ADV-010/0404/1000/GPC



THE CHALLENGE MACHINERY COMPANY
6125 Norton Center Dr. Norton Shores, MI 49441 USA
Phone: 231.799.8484 Fax: 231.798.1275 www.challengemachinery.com